

Design and Manufacturing of Special Purpose Machine for Drilling

¹Sairaj P Deshmukh , ¹Abhishek S Limaye , ¹Yogesh Bhalla , ²Rohit R Jadhao

¹UG Student, Department of Mechanical Engineering,
NMIET, SPPU Talegaon Dabhade, Pune-410507

² Asst Professor, Department of Mechanical Engineering,
Nutan Maharashtra Institute of Engineering and Technology

Abstract—The Special Purpose Machine (SPM) plays an important role to increase productivity. Most of the machines require settings every time we need to machine a component. Here the SPM designed for drilling is one such kind of Machine which consists of multi spindle drilling head. The Components are placed horizontally and held intact by the adftors. The spindle travels towards the component by a hydraulic force. Electric motor drives the spindle head containing drill. Operation of machine is very user friendly, fast and foolproof. This increases the productivity, accuracy and also machining time.

Keywords:- Special Purpose Machine, Multispindle Drilling, Productivity.

I. INTRODUCTION

In mass production system special purpose machines are used to increase productivity. In case of drilling operation multispindle drilling machines are used because it saves time by drilling two holes at same time. Due to saving of time in one operation it is possible to increase productivity of machining system.

Two spindles of machine are driven by a single motor simultaneously using step cone pulley and v-belt system. Drilling head is fixed on the side rails provided on the base of machining unit. This drilling head is moved using hydraulic cylinder. common problems faced by conventional machining are complicated jig and fixture design to hold component and guide drill bit, controlling drill depth, Pressure applied to handle of drilling machine, Human error while loading and unloading work piece on fixture, accommodate change in size of drill hole. To overcome all this problems this automated machine is designed.

To provide fixture for component two tandem cylinders are used which are bolted on the L bracket. These two cylinders are used to hold the circular job. On the L bracket jig bush is provided to guide drill bit on correct location. Other necessary accessories like coolant tank, coolant pipes, collection tray, plc

control board, box for plc kit and cover for other harmful moving components are provided.

All these operations are controlled by plc system, which will reduce human errors occurred during drilling.

II. LITERATURE REVIEW

- *A.S.Udgave et.al.* In this paper author studies and tries to study attachments for the radial drilling machine to make it special purpose machine. This will increase productivity and also reduces time. In this paper work is done on the currently going on job as well as it includes industrial case study. Multispindle head is developed to drill two holes simultaneously in one setting only. Two spindles are driven by a single motor with mechanism of changing speed. Different mechanism is given to the table and spindle head to adjust according to work piece. Also this paper gives information about types of multi spindle drilling head.
- *Dnyaneshwar Bharad et.al.* Here study of different parameters which is affecting the production capacity and time has been discussed. In the study author states that machining time required is main or one of the main parameter which will affect the efficiency of machine. Author also discusses about advantages of using two drilling heads over conventional drilling machine such as achieving two holes at the same time, less space required than any conventional drilling machine, only one driving motor required, etc.
- *Manish N Kale et.al.* In this author studies two different processes which can be achieved on single machine i.e. drilling and riveting on a single special purpose machine. Earlier drilling is done on a drilling machine after that for riveting operation component is setup on an orbital riveting spindle which is very time consuming process and apparently it will affect the productivity of the machining system. This problem is focused and solution is given to this problem. Along with this analysis of the machine parts

has been done by using different computer software's. Concluding all this things, time saved per job is 24.7 sec

- **Prof P.R. Sawant et.al.** have conducted case study on multi drilling and tapping machine. Here they have compared different parameters of the special purpose machine for drilling and tapping with the radial drilling machine. They have considered 7 holes of same diameter, 1 hole of larger diameter, 1 linear tapping operation, 1 angular tapping operation. By performing this operation on both machine they made the conclusion. What to do increase productivity and to enhance machining system. Advantages of automatic work handling and control system over the manual system also has been studied.
- **Yaman Patel et.al** studies different problems that are restricting mass production rate and develop a new drilling machine in which the main purpose is to minimize time required for drilling holes on different PCD and also paper deals with the improvement of cycle time.
- **Mr. K.K.Powar et.al** states the importance of developing special purpose machine their requirement for the industry to increase rate of production along with increasing quality of the production. Here different attachment to right side and left side has been developed to achieve multi orientation drilling subsystem. Also statistical process control has been carried out to study the results achieved by special purpose machine and their feasibility and accuracy.

III. OVERVIEW OF MACHINE

The SPM is designed for operation on a cylindrical job which needs a hole to be drilled. Some of the components are given below:-

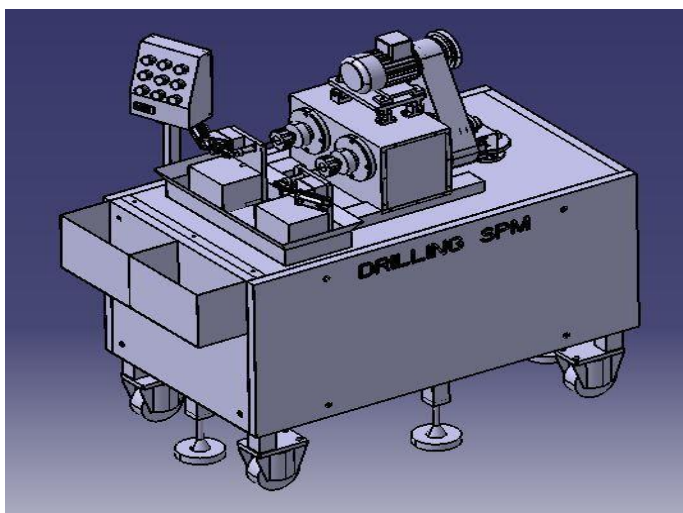

Fig 1: Overview of Machine

A. Components of Machine

- **Spindle Shaft-** In this SPM 2 spindle shafts are used, which will hold the drill bit and provide a necessary support for the drill bit. Also a hollow shaft is to be used, so that the weight is reduced and to increase the strength and stop the spindle in least possible time. Hollow shafts are much better to take tensional loads compared to solid shafts. Also has greater strength to Weight ratio. Here the Spm contains two spindles.
- **Pneumatic Cylinders:-** There will be a pneumatic feed for drilling. A pneumatic cylinder is used to transmit the entire setup and to start machining the component by a rotating spindle. The pneumatics transmits a large force on small compressions and also gives a smooth and continuous speed. Here total 3 cylinders are used i.e. one for feed the block containing spindles and 2 for fixtures to hold the work piece tight.
- **Electric Motor:-** Here it is used to transmit motion for the two driven pulleys which will drive the spindle for drilling. And also produce necessary speed and torque required for operation. 0.5 hp motor is used in this operation.

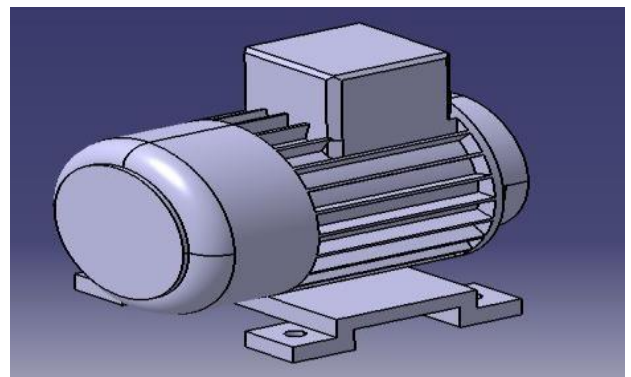

Fig 2: Stepper Motor

- **Step Cone Pulley:-** The cone pulleys here are required for transmitting required torque and variation of speed by adjusting the belts in a proper groove .V-Belt is used to transmit higher power and torque and also avoid slip between pulley and belt.

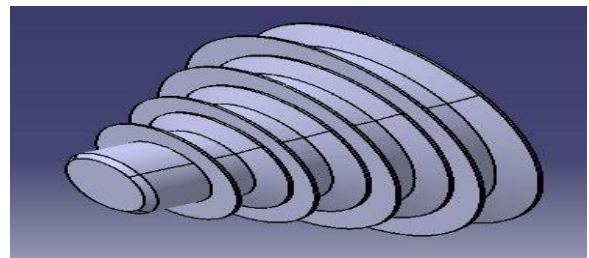

Fig 3: Step Cone Pulley

- **Jig and Fixtures:-** This eliminate the frequent positioning, marking, checking of individual component. Also guiding of the drill in the component becomes easy. Fixture locks DOF of component to avoid misplacement due to vibrations.

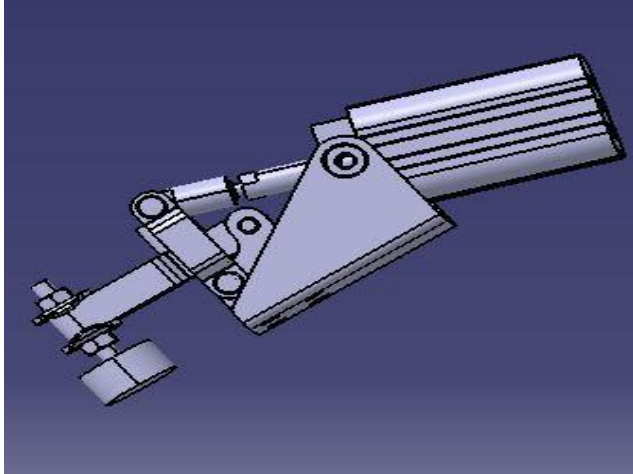

Fig 4 : Jig Fixture

- **Coolant Tank:-** Coolant tank is necessary to reduce cutting tool temperature since a small reduction in cutting tool temperature will greatly extend cutting tool life. Coolant is applied during machining operations, removes heat by carrying it away from cutting tool or work piece interface. Here Coolant tank stores the coolant.
- **PLC Control in SPM:-** A programmable logic controller, PLC, or programmable logic controller is a digital computer used for automation of typically industrial electromechanical processes, such as control of machinery. In SPM the PLC programming is to control the machine and also make the machine automatic up to possible extent. . Here plc controls the entire setup for drilling, clamping the component, motor control, drilling feed.

IV. DESIGN OF DRILLING SPM COMPONENTS

1. **Motor Selection:-** we have selected a motor of following specification , three phase induction motor. Power=0.5 hp=375W, speed=1380rpm.

- To calculate arbor Shaft Torque:- Power = (2πNT/60)
T=2.5944 N-m
Motor is 375 watt power, running at 1380rpm, connected to drilling machine spindle by belt and pulley arrangement of 1:3 ratio, considering 66% efficiency, torque at the arbor shaft is given by:-
- T motor x 3 x 0.66= 2.5944 x 3 x 0.66 = 5.138 N-m

2. **Design of Spindle Shaft:-** M = bending moment T

= twisting moment

Maximum HP to be transmitted by pulley = 0.5 hp N = 460 RPM

Angle of deflection = 0.25⁰ = 0.00436 rad. Let

T = torque transmitted by shaft

$$T = P \cdot 60 / 2\pi N$$

Thus diameter of shaft is given by;

T/J = Gθ/L and using J = (π/32)*(d⁴) we get diameter as 'd' mm.

3. **Design of Pneumatic Cylinders:-**

Force = Effective piston area x operating pressure x Efficiency F=A*p*η

- Effective area for advanced stroke;
A_a = d² x p /4; where d₁=cylinder diameter

- Force for advance stroke;
F_a = p x A_a x h; where h=efficiency factor

- Effective area for return stroke;
A_r = (d² x p/4) - (d² x p/4) ; where d₂= piston rod diameter

- Force for return stroke; Fr= p×Ar×h ; N

- Cylinder air consumption;
Q = (A₁+A₂) ×s×n× (Patm+Pe/Patm)×(1/1000);

Q= Air consumption of double acting cylinder (l/min)

A₁= Effective piston area advance stroke (cm²) A₂= Effective piston area return stroke (cm²) s= Piston stroke (cm)

n =Cycles per minute

p_{at} =atmospheric pressure (bar) p_e =operating pressure (bar)

V. WORKING OF DRILLING SPM

A multi-spindle drilling attachment is mount on the drilling machine spindle sleeve. Cutting tools as per requirement of the job can be fixed into the chuck. Electric motor is used as a prime mover to drive the spindles with the help of a belt and pulley arrangement. The entire block containing the drilling setup is traversed along the guide ways with the help of Pneumatic cylinder. Pneumatic feed delivers larger force upon small compression of air, thus a gradual smooth operation is possible. The jig and fixtures are used for holding the component fixed at a position to maintain accuracy and precision while drilling. A hole of Ø 2.5 mm diameter and 8 mm deep hole is to be drilled in each of the components. The operation of entire machine is made very easy to operate; it is automatic and is also controlled by PLC system.

There is comparison given between Pillar drilling machine, M1-TR drilling machine and Drilling SPM in the following.

In this comparison all the parameters of M1-TR machine and pillar drilling machine was taken actually while parameters of the drilling Spm calculated theoretically.

Parameters	Pillar Drilling Machine	M1-TR Drilling Machine	Drilling SPM
Machine Cost	60,000	3,05,000	1,75,000
Cyclic Time / Job	65	100	15
Jobs/ Shift(8hrs)	443	288	1920
Target(1800 jobs/shift)	Cannot be achieved	Cannot be achieved	can be achieved
Cost of per job (in Rs.)	12	16	6

Table. 1: Comparison of Parameters on Different Machines

Therefore Pillar drilling machine and M1-TR drilling machine result in lower production rate. Hence using SPM, the total cyclic time is reduced up to only 15 seconds. A greater result is seen in terms of production rate which can produce 1920 components in one shift of 8 hrs/day.

VI. APPLICATIONS

Mostly drilling SPM is used for drilling a variety of holes of different sizes. Also as per requirement of the industry or design of component, different operations can be done such as reaming, countersinking, tapping, etc. just by changing the tool and jig and fixtures designed for the component.

A. Advantages of using Special Purpose Machine:-

- It will reduce time required for drilling a hole.
- As cycle time is reduced cost required for one component is also reduced.
- It will save energy consumption
- No skilled operator is required.

VII. CONCLUSION

By using multi-spindle drilling head productivity will increase. With the conventional machine, drilling requires 65-100 seconds. Whereas SPM requires merely 15 seconds for completing each component. The production rate is approximately 4 times by using multi-spindle drilling head in SPM. In case of production of other batch or other job with different operations, the same machine can be operated by removing the multi-spindle drilling attachment with different tools.

REFERENCES

- [1]. A.S.Udgate, Prof.V.J.Khot "Design & development of multi spindle drilling head" (msdh) OSR Journal of Mechanical and Civil Engineering (IOSR-JMCE) ISSN: 2278-1684, PP: 60-69
- [2]. Dnyaneshwar B Bharad, Rahul D Gawande, Pratik D Ghangale, Rahul K Gunjal, Prof.A.S.Autade, Prof.P.P.Darade "A Paper on Two Spindle Drilling Head"
- [3]. Manish N. Kale "Design and Analysis of Special Purpose Machine for Drilling and Riveting Operation"
- [4]. Prof. P.R. Sawant, Mr. R. A.Barawade "Design and Development of SPM-A Case Study In Multi Drilling And Tapping Machine", E-ISSN2249-8974
- [5]. Yaman Patle, Nikalas Bhandakkar, Prashant Wangarwar, Pranay Thakre, Sagar Awachat, Ms. Manisha Fande Design and Fabrication Multi Spindle Drilling Machine with Different Pitch Hole
- [6]. Mr.K.K.Powar,Prof.(Dr)V.R.Naik, Prof.G.S.Joshi "Design & development of multi orientation drilling special purpose machine subsystem"
- [7]. Smit Patel, Sahil Vasoya, Ankur Joshi "Design And Manufacturing Of Jigs For Drilling Machine"
- [8]. Kishan Vyas, Dharmik Patel, Ruchit Patel Arun Chauhan "A Review Paper on Development for Drilling and Riveting Operation International Journal of Advance Engineering and Research Development"
- [9]. Shinde Nikhil, Vishwakarma Prem, Sanjay Kumar, Godse Rahul, P.A. Patil "Design & Development of Twin Drill Head Machine and Drilling Depth Control" International Journal of Innovative Research in Science, Engineering and Technology
- [10]. Praveenkumar, B. S., Niranjana Hugar, Ajithkumar, "A Design Of Rod Grooving Multispindle Drilling Unit" Asian Journal of Science and Technology.