

Design of a Modernized Cassava Peeling Machine

Onyenobi Chinwendu Samuel, M.Eng, IAENG, MNSE,
COREN, RAESON (Author)
Mechanical Engineering Department, Federal Polytechnic
Nekede, Nekede, Nigeria

Ikenga Emmanuel, B.Eng, PGDE, PGD (Co-Author)
Mechanical Engineering Department, Federal Polytechnic
Nekede, Nekede, Nigeria

Abstract:-The design of a modernized cassava peeling machine was carried out in this paper. The principles of engineering design and application using a motorized screw mechanism of helical metal wires were adopted on a rigid shaft powered by an electrical motor of 1 Hp and applied in the design of the peeling chamber which is cylindrical in shape. The peeling drum was designed with 1.5 mm thick steel flat sheet. The total mass of cassava per batch in the peeling drum was designed to be 20 kg with weight of 196.2 N occupied in a peeling chamber of volume 0.978136m³. For 30 minutes of peeling, the peeling force required, F_p is 8.437N when the velocity is 25.31m/s. The torque made by the shaft at the peeling chamber is 2.374 Nm and torsional stress of the shaft was found to be 6.88 x 10⁵ N/m². The efficiency of the machine was designed to be 80% at a power output of 42.28 Watt.

Keywords:-Modernized Cassava Peeling Machine, Screw Mechanism.

I. INTRODUCTION

Cassava is a dicotyledonous perennial plant whose tuber is very useful in the world especially in the African Continent where it is utilized in the production of starch, garri, akpu, semo, floor, animal feed etc. The processing of cassava tuber to these products requires the removal of the tuber bark and the process of cassava peeling is always applied. There are many peeling methods which can be applied to remove the cassava tuber's bark through a process known as peeling namely: manual peeling by humans (using knife), chemical peeling (using hot solution of sodium hydroxide to loosen and soften the skin) according to Igbeka, 1985, and mechanical peeling using machines. The use of machines in peeling of cassava is always faster and saves time in processing of large number of cassava tubers.

The design of cassava peeling machine has been carried out by some African scholars but the industrial application of these designs over the years have proven some difficulty especially in handling of cassava tubers with varying sizes and shapes using either the screws method, abrasives method or the attritions method. Odigboh (1983) has developed three models of cassava peeling machine which was called model I,

II and III. In model I, an oil drum was punched about two third millimeter diameter holes per square cm of its surface and eccentrically mounted on shaft with 200mm by 150mm opening which was made to load cassava inside the drum. Cassava tubers and a predetermined quantity of some inert materials such as quartziferous pebbles of 3.2-4.8mm hard quarry stones are loaded into the drum which was rotated at 40r.p.m. The rubbing action of the pebbles on the cassava tuber removed the bark thereby leaving the cassava peeled. There is uniform peeling in this process. Water is being sprayed to wash the finely abraded peels to prevent fouling and dulling of the abrasive surface as discussed by Odigboh (1983). In model II, according to Odigboh (1983), balls of expanded metals were used to replace the pebbles. Model III, had four abrasive cylinders of expanded metal mounted inside the main peeling drum driven by a planetary gear arrangement made to rotate about their axes at four times the r.p.m of the main drum and rotated at 40 r.p.m. Odigboh (1983).

The design of cassava peeling machine using an abrasive mechanism has been carried out by Alhassan et.al, (2018). In the design consideration of the cassava peeler, the quality of the food as well as the longevity of the material for use in fabrication was put into consideration (Alhassan et.al, 2018). In consideration for preservation of the quality of food, the fabrication materials to be selected should not contaminate the food and must possess properties capable of resisting corrosion, wear and tear. The affordability and local availability of materials as well as the strength of the material for construction must be considered (Alhassan et.al, 2018). The physical and chemical properties of the cassava tuber to be peeled were given due consideration such as the specific weight, density, size, impact, tensile and compressive strength (Alhassan et.al, 2018). Experimental procedure by Alhassan et.al, 2018 has shown that slow speed rotation of 58 r.p.m with 2.5, 8.7 and 12.5 kg feed rate led to an improved peeling action when peeling was performed at this speed. It was practically observed that a slow speed favours the machine operation and this was achieved using a reduction gear (Alhassan et.al, 2018). The percentage Peeling efficiency (P_E) can be estimated as the ratio of the mass of cassava to be peeled in a batch in unit time to the mass fraction g , of the peeled cassava expressed in percentage (Abdulkadir, 2012).

II. LITERATURE REVIEW

Cassava originated from South Africa and is scientifically known as *Manihotesculentacrantz*. The design and fabrication of cassava peeling machine has been carried out by many researchers including Ajibola&Babarinde,2016. In their design, the efficiency of peeler was determined as the ratio of the thickness of tuber peeled by the machine to the ideal thickness to be peeled and expressed in percentage (Ajibola&Babarinde, 2016). In their design analysis and calculation, the speed ratio was determined as 6.5, velocity of 91.42m/s, power output of 51.51 KW, and power input of 64.39 KW lead to a machine efficiency of 79% when the torque generated is 136.63 Nm and speed of the driven pulley is 556.70 r.p.m.(Ajibola&Babarinde, 2016). The mass of cassava to be peeled per batch was 20kg and total mass of the peeling drum with the mass of cassava to be peeled, mass of the cleaner, mass of the brush and mass of the shaft was 57.44 Kg (Ajibola&Babarinde, 2016). The power required to drive the machine was 13hp which is equivalent to 9.698KW.Much power was required to run this machine. This is a problem identified in their design. The configuration of the machine by Ajibola&Babarinde, 2016 is of size 970×770×1380 mm. The volume of the peeling drum is 0.260 m³. Therefore, there is need to reduce the power to a considerable minimum with an improved efficiency and compact design, hence modernization becomes very necessary.

III. MATERIALS AND METHOD

A modernized cassava peeling machine was designed using the principles of engineering design. The material consideration was made during the design application. Factors like strength of the material, corrosion, affordability and local availability of material for construction was considered. The physical and chemical properties of the cassava tuber to be peeled were given due consideration such as the specific weight, density, size, impact, tensile and compressive strength were all considered for effective design.

❖ *Materials*

The lists of materials for the design are listed below:

- i. 1HP electric motor
- ii. V-belt
- iii. Pulley of diameter ϕ 290mm and ϕ 110mm
- iv. Mild steel angle iron 50× 50mm in size
- v. Flat bar 50mm thick and 20mm thick
- vi. Cylindrical rod
- vii. Cylindrical shaft ϕ 26mm
- viii. Stainless flat sheet of 1.5mm thick
- ix. Bearing with internal diameter ϕ 26 mm
- x. 2.5mm thick metal flat sheet
- xi. 1.5mm thick galvanized flat sheet

❖ *Methods*

The methodology for the design and fabrication of the modernized cassava peeling machine is shown below in steps. Step 1 – feasibility study of existing project.

- Step 2 - market survey of cost and availability of materials
- Step 3- design drawing- isometric and orthographic projection
- Step 4 – design analysis and calculation

➤ *Feasibility study of existing project*

Feasibility study of already existing project was carried out. Information from journals published by various scholars was used in assistance for the design. The mechanism of peeling operation and parts of the peeling machine was observed in prevision projects done by various authors and there was improvement in the present project.

➤ *Market survey*

The price and availability of materials were checked in the market with respect to material selection. The properties of the materials were considered such as strength of the materials, durability, fatigue, machinability, shape, strength and other factors were all considered.

➤ *Design analysis and calculation*

The following design considerations made and applied in the project design analysis:

The mass of cassava to be peeled on a batch =20kg

The weight w = mg of the cassava to be peeled in a batch = (20× 9.81) = 196.2N

➤ *Calculation of the peeling chamber volume, V_p*

The peeling chamber is cylindrical in shape. Therefore the volume will be the volume of the cylinder.

$$V_p = \frac{1}{3} \pi r^2 h \quad \dots(1)$$

$$V_p = 1/3 \times 3.142 \times (300/1000)^2 \times (1153/1000) m^3$$

$$V_p = [1/3 \times 3.142 \times 0.09 \times 1.153] m^3$$

$$V_p = 0.978136 m^3$$

➤ *Estimation of peeling force of the machine*

Let the peeling force be F_p.

There will be a relationship between the mass of the cassava, the linear velocity of the belt transmission, and time of peeling, t such that F_p= ma. Where a, is the acceleration of the motor with respect to the cassava in the peeling chamber.

$$F_p = \frac{mv}{t} \quad \dots (2)$$

For 30minutes of peeling, the peeling force required

$$F_p = \frac{20kg \times v}{1800}$$

$$\text{But } V = \frac{2\pi r N}{t} \quad (\text{Khurmi \& Gupta 2008}) \quad \dots (3)$$

Where, r is the radius of the pulley, N is the number of revolutions of the motor 3000r.p.m, and t ,is the time required for peeling the cassava tuber. The velocity to be applied during peeling, V is given as:

$$V = \frac{2 \times 3.142 \times 145 \times 3000}{1800 \times 60}$$

$$V = 25.31 \text{ m/s}$$

The force required for peeling the cassava tuber, F_p is given as

$$F_p = \frac{20 \times 25.31}{60} = 8.437 \text{ N}$$

➤ *Belt design*

In the belt design, an applicable equation is

$$2.3 \log \left(\frac{T_1}{T_2} \right) = \mu \theta$$

where, θ = angle of wrap of open belt.

μ = co-efficient of friction
 T_1 = tension in the tight side of
 T_2 = tension in the slack side of the belt.

x = distance between the pulley
 \times Pulley of shaft (peeler)
 $d_2 = 290 \text{ mm}$

For cross belt, angle of contact is given by,

$$\sin \alpha = \frac{r_1 + r_2}{x} \quad \dots (4)$$

$$= \frac{55 + 145}{800}$$

$$\sin \alpha = 0.25,$$

$$\alpha = \sin^{-1}(0.25)$$

$$\alpha = 14.478^\circ$$

For open belt, angle of contact is given by. The belt used here is an open belt. Therefore,

$$\sin \alpha = \frac{r_1 - r_2}{x} = \frac{55 - 145}{800}$$

$$\sin \alpha = -0.1125$$

$$\therefore \alpha = \sin^{-1}(-0.1125)$$

$$\alpha = 6.459^\circ$$

Angle of wrap, θ is given by the expression,

$$\theta = 180^\circ \pm 2 \sin^{-1} \left(\frac{r_1 - r_2}{x} \right) \quad \dots (5)$$

$$\theta = 180^\circ + 2 \sin^{-1} \left(\frac{145 - 55}{800} \right)^\circ$$

$$\theta = 180^\circ \pm 2 \sin^{-1} \left(\frac{90}{800} \right)^\circ$$

$$\theta = 180^\circ \pm 2 \sin^{-1}(0.1125)$$

$$\theta = 180 \pm 12.9189$$

$$\theta = 180 + 12.9189 \text{ or } 180 - 12.9189$$

$$\theta = 192.9189^\circ \text{ or } \theta = 167.0811^\circ$$

Let r = radius of small pulley

R = Radius of big pulley

x = Distance between the two pulleys for peeling machine with inner rotating drum the angle of contact is solved below:
 For open belt, angle of contact is given by:

Angle of wrap, θ

$$\theta = 180^\circ \pm 2 \sin^{-1} \left(\frac{r_1 - r_2}{x} \right)$$

r = radius of small pulley

R = radius of big pulley

x = distance between the two pulleys

V = Velocity ratio of the driving pulley to the driven pulley is given by

$$\pi d_1 N_1 = \pi d_2 N_2$$

$$\text{Velocity ratio of the pulley} = \frac{N_2}{N_1} = \frac{d_1}{d_2} \quad \dots (6)$$

Where N_1 = Number of revolution of electric motor

N_2 = Number of revolution of the shaft at peeler.

$$\text{Velocity ratio of the pulley} = \frac{110}{290} = 0.38$$

$$N_2 = N_1 \times \frac{d_1}{d_2} = 3000 \times \frac{110}{290} = 330 \text{ r.p.m.}$$

Let power transmitted by the belt be P , where the belt speed be V .

$$P = (T_1 - T_2) \cdot V \quad \dots (7)$$

$$746 = (T_1 - T_2) \times 25.31$$

$$\therefore T_1 - T_2 = \frac{746}{25.31} = 29.47 \text{ N}$$

Where, P = belt power (W),

V = belt speed (m/s)

T_1 and T_2 are tensions on the tight and slack sides respectively (N)

But, the power transmitted by the belt will be the power of the motor,

$$P = 1.0 \text{ Hp} = 746 \text{ Watt and } V = 25.31 \text{ m/s}$$

$$\text{But } (T_1 - T_2) = 29.47 \text{ N}$$

Using belt ratio for an open belt,

$$2.3 \log \left(\frac{T_1}{T_2} \right) = \mu \theta \quad \dots (8)$$

Where, μ = coefficient of friction between belt and pulley

For mild steel pulley and rubber belt, $\mu = 0.30$

If m is the mass of the belt, then m = Area of belt \times length of belt \times density of belt

$$\therefore \text{Centrifugal tension of belt, } T_C \text{ is given by } T_C = M \cdot (V^2/r) \quad \dots (10)$$

Maximum, tension of the belt, T_{max}

$$T_{\text{max}} = M \cdot (V^2/r)$$

Maximum tension of the belt

$$T_{max} = \sigma \times \alpha$$

Where, σ = the stress of the material of the belt and α = the acceleration of the belt.

The Length of belt, L can be determined by,

$$L = \pi (r_2 + r_1) + 2x + \left(\frac{r_1 - r_2}{x}\right)^2$$

(Khurmi & Gupta 2008)

$$L = 3.142 (145 + 55) + 2(800) + \left(\frac{145 - 55}{800}\right)^2$$

$$L = (3.142 \times 1810.125) \text{ mm}$$

$$L = 5726.3 \text{ mm}$$

➤ **Design of the shaft**

Polar moment of inertia, J of the round solid shaft selected is calculated according Khurmi & Gupta 2008. The shaft selected is 260 mm. Therefore, J is can be calculated as:

$$J = \frac{\pi}{32} \times d^4 \quad (\text{Khurmi \& Gupta 2008}) \quad \dots (11)$$

$$J = \frac{3.142}{32} \times \left(\frac{26}{1000}\right)^4$$

$$J = \frac{3.142}{32} \times (0.026)^4$$

$$J = \frac{3.142}{32} \times 4.57 \times 10^{-7}$$

$$J = \frac{14.36}{32} \times 4.57 \times 10^{-7} = 0.44875 \times 10^{-7} = 4.49 \times 10^{-8} \text{ m}^4$$

The twisting moment or torque made by the shaft, T is given by

$$T = \frac{\pi}{16} \times \tau \times d^3 \text{ where } \tau \text{ is the torsional shear stress, and } d \text{ is the diameter of the shaft.}$$

Similarly, mean torque transmitted by the shaft,

$$T_{mean} = \frac{P \times 60}{2\pi N} \quad \dots (12)$$

$$\frac{\pi}{16} \times \tau \times d^3 = \frac{P \times 60}{2\pi N}$$

Where P is the power transmitted by the shaft = 1Hp = 746 Watt

$$T_{mean} = \frac{746 \times 60}{2 \times 3.142 \times 3000}$$

$$T_{mean} = \frac{44760}{2 \times 3.142 \times 3000} = 2.374 \text{ Nm.}$$

Since the mean torque, T_{mean} made by the shaft at the peeling chamber is 2.374Nm.

$$\therefore 2.374 = \frac{3.142}{16} \times \tau \times \left[\frac{26}{1000}\right]^3$$

$$2.374 = \frac{3.142}{16} \times \tau \times 1.7576 \times 10^{-5}$$

$$\tau = \frac{2.374 \times 16}{3.142 \times 1.7576 \times 10^{-5}}$$

$$\tau = \frac{37.984}{5.52 \times 10^{-5}}$$

$$\tau = \frac{37.984 \times 10^5}{5.52}$$

$$\tau = 6.88 \times 10^5 \text{ N/m}^2$$

The torsional shear stress of the shaft, $\tau = 6.88 \times 10^5 \text{ N/m}^2$

➤ **Bending moment of the shaft**

Let M be the bending moment of the shaft.

The maximum torsional stress, τ_{max} has relationship with the bending moment, M, the diameter of the shaft, d and the torque T,

$$\tau_{max} = \frac{1}{2} \sqrt{(\delta b)^2 + 4\tau^2} \quad (\text{Khurmi \& Gupta 2008}) \quad \dots (13)$$

Where, δb is the bending stress (tensile or compressor) induced stress due to moment.

For 40C8 shaft material, $\delta b = 320 \text{ MPa}$

$$\tau_{max} = \frac{1}{2} \sqrt{(320 \times 10^6)^2 + 4 \times (6.88 \times 10^5)^2}$$

$$\tau_{max} = \frac{1}{2} \sqrt{102400 \times 10^{12} + 189.3376 \times 10^{10}}$$

$$\tau_{max} = \frac{1}{2} \sqrt{102400 \times 10^{12} + 1.893376 \times 10^{12}}$$

$$\tau_{max} = \frac{1}{2} \sqrt{102400 \times 10^{12}}$$

$$= 1.6 \times 10^{14} \text{ N/m}^2$$

But the bending moment of inertia M can be calculated from,

$$\tau_{max} = \frac{1}{2} \sqrt{\left(\frac{32M}{\pi d^3}\right)^2 + \left(\frac{16T}{\pi d^3}\right)^2}$$

$$\tau_{max} = \frac{16}{\pi d^3} \sqrt{M^2 + T^2} \quad \dots (14)$$

$$1.6 \times 10^{14} \text{ N/m}^2 = \frac{16}{3.142 \times 1.7576 \times 10^{-5}} \times \sqrt{M^2 + 2.374}$$

$$= \frac{16}{5.522 \times 10^{-5}} \times \sqrt{M^2 + 2.374}$$

$$1.6 \times 10^{14} \text{ N/m}^2 = 2.897 \times 10^5 \times \sqrt{M^2 + 2.374}$$

$$\frac{1.6 \times 10^{14}}{2.897 \times 10^5} = \sqrt{M^2 + 2.374}$$

$$0.5522955 \times 10^{19} = \sqrt{M^2 + 2.374}$$

$$5.522955 \times 10^{18} = \sqrt{M^2 + 2.374}$$

Square both sides to remove square root

$$(5.522955 \times 10^{18})^2 = M^2 + 2.374$$

$$30.503032 \times 10^{36} = M^2 + 2.374$$

$$M^2 = (30.503032 \times 10^{36} - (2.374))$$

$$M = \sqrt{30.503032 \times 10^{36} - 2.374}$$

$$M = 5.522955 \times 10^{18} \text{ Nm.}$$

➤ *Efficiency of machine*

The efficiency of the peeling machine can be calculated by estimation of power output P_o , and the power input P_{in}

Power output P_o = force causing peeling of cassava \times velocity at which the cassava is being turned.

$$P_o = F \times V = 8.437 \times 5.01149$$

$$P_o = 42.28\text{W} = 0.04228\text{Kw}$$

But $V = r_1 W_1$, Where W_2 and W_1 are the angular velocities for input and output respectively.

$$W_2 = \frac{2\pi N_2}{60} \text{ and } W_1 = \frac{2\pi N_1}{60}$$

$$W_2 = \frac{2 \times 3.142 \times 330}{60} \text{ and } W_1 = \frac{2 \times 3.142 \times 3000}{60}$$

$$W_2 = 34.562\text{rad/s} \text{ and } W_1 = 314.2\text{rad/s}$$

$$\text{Efficiency, } \eta = \frac{\text{power output, } p_o}{\text{power input, } p_{in}} \times 100\% \dots (15)$$

If the efficiency of the machine is to be designed for 80% efficiency, then the input power can be estimated as:

$$\frac{80}{100} = \frac{42.28}{p_{in}}$$

$$0.8 = \frac{42.28}{p_{in}}$$

$$p_{in} = \frac{42.28}{0.8}$$

$$= 52.85\text{W}$$

$$= 0.05285\text{Kw}$$

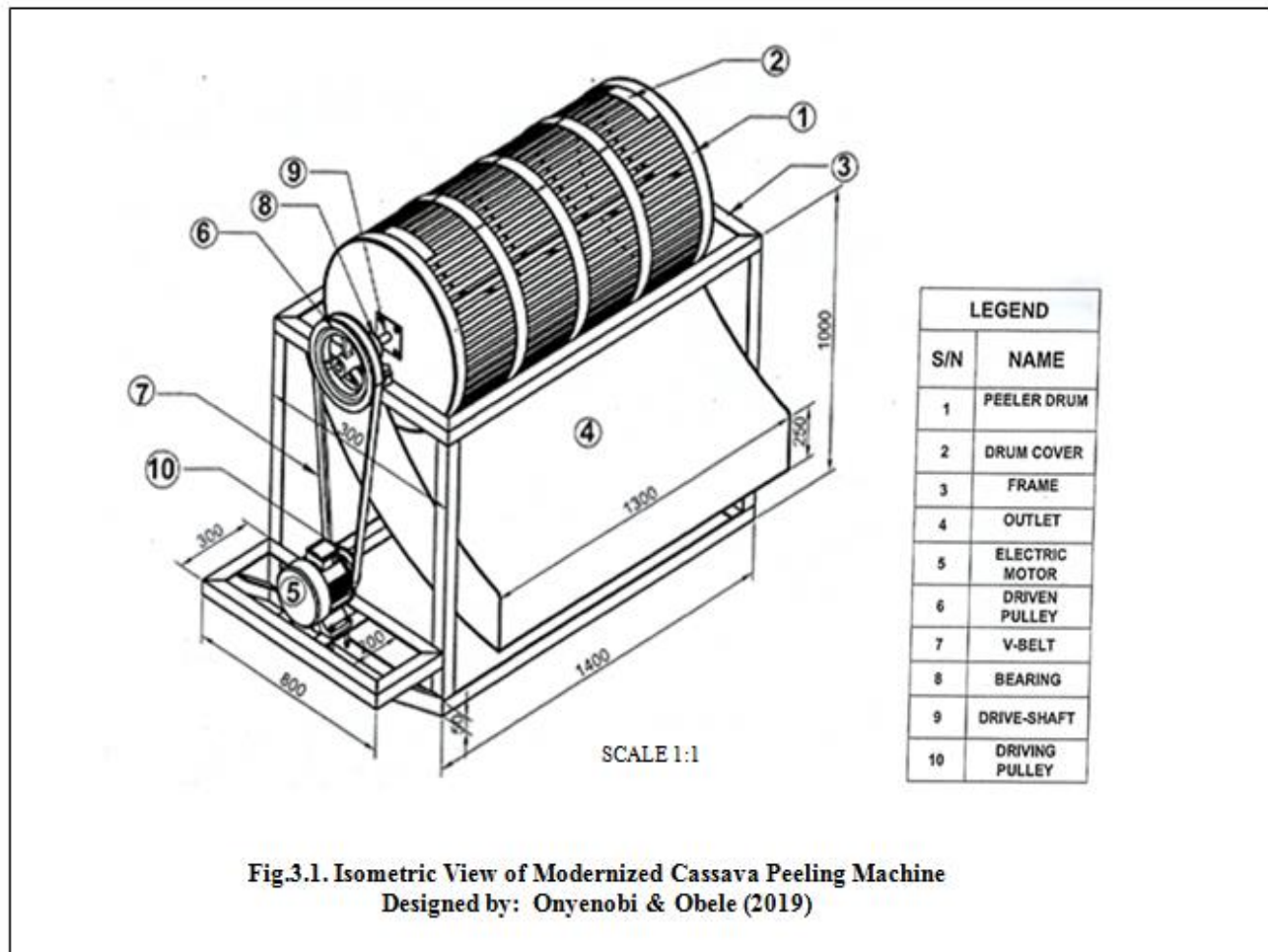

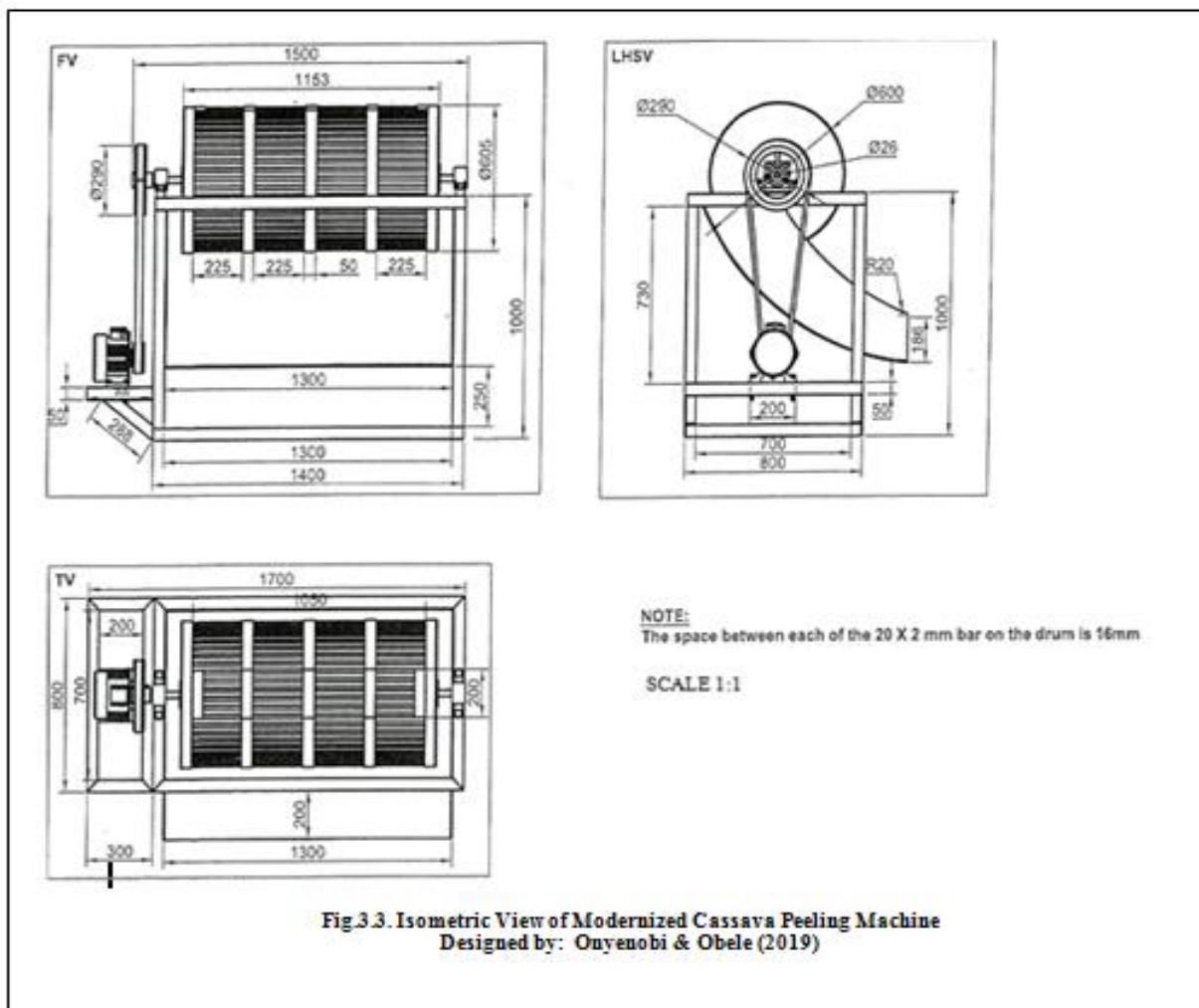
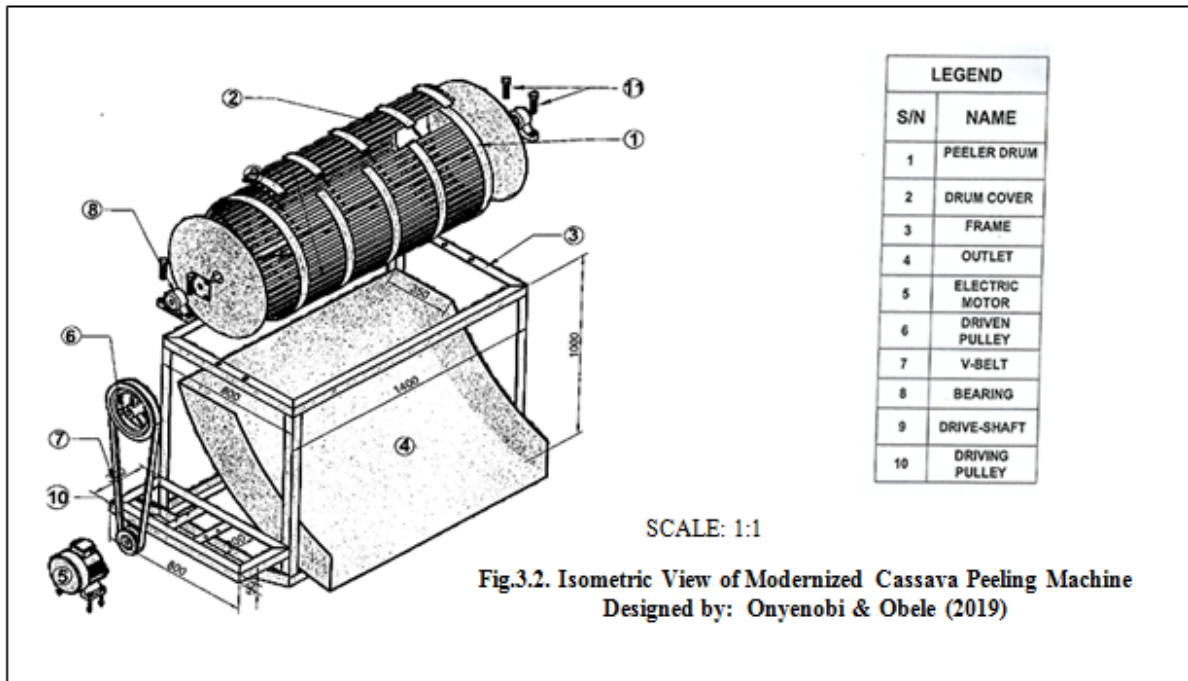

S/N	DESCRIPTION	QUANTITY	UNIT COST (₦)	AMOUNT (₦)
1	1HP electric motor	1	25,000	25,000.00
2	V-belt, L = 5726.3mm	1	1,000	1,000.00
3	Pulley of diameter ϕ 290 mm	1	2,000	2,000.00
	Pulley of diameter ϕ 110 mm	1	2,000	1,500.00
4	Mild steel angle iron 50 X 50 mm in size	2 full lengths	7,500	15,000.00
5	Flat bar 50mm thick and 20 mm thick	4 full lengths	1,200	4,800.00
6	Cylindrical rod	7 full lengths	900	6,300.00
7	Cylindrical shaft ϕ 26 mm of 2,000 mm length	1	3,500	3,500.00
8	Stainless flat sheet of 1.5 mm thick	1	30,000	30,000.00
9	1.5mm thick galvanized flat sheet	1 full sheet	12,000	12,000.00
10	Bearing	2 pieces	2,000	4,000.00
11	2.5mm thick metal flat sheet	1/3 of full sheet	15,000	5,000.00
12	Electrode of gauge 12	1 packet	2,500	2,500.00
13	Auto paint	2 litres	2,500	2,500.00
14	Glossy finish	2litres	2,500	2,500.00
15	Thinners	2litres	2,000	2,000.00
16	Sand paper rough	1meter length	500	500.00
17	Sand paper smooth	1meter length	500	500.00
18	Body filler	½ of full tin	6,500	3,250.00
19	Sub Total cost of material	-	-	123,850.00
20	Labour 15% of Sub total cost of material	-	-	18,577.5
21	Vat 5% of Subtotal cost of material	-	-	6,192.5
22	Total Cost of Production	1 unit machine	-	₦ 148,620.00

Table 1:- Bill of Engineering Measurement and Evaluation for the Design and Fabrication of A Modernized Cassava Peeling Machine

IV. DISCUSSIONS

➤ Materials

1HP electric motor was suitable and applied in the design to turn the shaft in the peeling chamber with the helical coils in screw form attached on it. The shaft was not overloaded and V-belt was applied and length of belt determined appropriately to avoid belt sagging and ensure proper tensioning. Appropriate pulley sizes for the driver and driven was considered and selected properly. The material used in the design of the peeling chamber is a stainless flat sheet of 1.5mm thick which can resist corrosion and is strong to withstand the stress introduced to the peeling chamber during operation. Mild steel angle iron of 50 X 50 mm size was suitable for the design of the frame of the machine as it is strong enough to withstand vibration which can arise from the motor and peeling chamber during operation.

➤ Method

The methodology for the design and fabrication of the modernized cassava peeling machine was followed to step by step to achieve the design. In the first step, feasibility study of existing project was carried out. Most existing projects have higher power consumption as a result of the electric motor applied. This present design put this into consideration and lowered the power consumption. In the second step, there was market survey to ascertain the cost and availability of materials in the market. This helped to estimate the cost of the machine after fabrication to avoid making a design that will be too high in terms of cost. The third step included the design drawings, the isometric and orthographic projection which showed clearly the designed machine parts. The drawings were used in design analysis and calculations which was the fourth step of the design process to ensure workability, assembling of parts and accuracy during the machine fabrication after the design has been completed.

➤ Design analysis and calculation

In the design analysis and considerations, the mass of cassava to be peeled on a batch per batch was 20 kg. The weight of the cassava to be peeled per batch in the peeling chamber was 196.2 N.

This together with the weight of the shaft and material for the peeling drum constituted the design load.

➤ Calculation of the peeling chamber volume, V_p

The peeling chamber is cylindrical and the volume, $V_p = 0.978136 \text{ m}^3$ was determined by using the formula of the volume of a cylinder. The volume was good enough to accommodate the cassava per batch.

➤ Estimation of peeling force of the machine

The peeling force was estimated. The relationship between the mass of the cassava, the linear velocity of the belt transmission, and time of peeling, t was considered in the estimation. The acceleration of the motor with respect to the cassava in the peeling chamber for 30 minutes of peeling was used to determine the peeling force of 8.437 N. A motor speed of 3000 r.p.m was applied in the design and a velocity $V = 25.31 \text{ m/s}$ was achieved for peeling the cassava. The design avoided the application of reduction gears as applied by other designers because of the presence of the helical screw coils which helped in reduction of speed and improves peeling action.

➤ Belt design

The belt design was carried out and the length of belt, L determined according to Khurmi & Gupta 2008. L was found to be 5726.3mm and the angle of contact for the open belt used was determined as $\alpha = 6.459^\circ$. The velocity ratio of the pulley was found to be 0.38. The difference in tension between the tight and slack sides of the belt was calculated to be 29.4N. These were applied in the design of the modernized cassava peeling machine.

➤ Design of the shaft

In the design of the shaft, the polar moment of inertia, J of the round solid shaft selected was calculated. The shaft selected is 260mm. Therefore, J was calculated according to the formula by Khurmi & Gupta 2008 and found to be $4.49 \times 10^{-8} \text{ m}^4$. The twisting moment or torque made by the shaft, T was also calculated and the mean torque transmitted by the shaft found to be 2.374 Nm . The torsional shear stress of the shaft was calculated and found to be $6.88 \times 10^5 \text{ N/m}^2$.

➤ Bending moment of the shaft

The maximum torsional stress τ_{\max} has relationship with the bending moment, M , the diameter of the shaft, d and the torque (Khurmi & Gupta 2008). For 40C8 shaft material, $\delta b = 320 \text{ MPa}$. The maximum torsional stress

τ_{\max} , was determined as $1.6 \times 10^{14} \text{ N/m}^2$ and the bending moment, M has the value of 916 Nm. The material for shaft must be of higher stress value and bending moment to avoid distortion and bending during machine operation.

➤ Efficiency of machine

The efficiency of the peeling machine was calculated by estimating the power output P_o , and the power input P_{in} . The Power output, $P_o = \text{force causing peeling of cassava} \times \text{velocity at which the cassava is being turned}$. Power output was 42.28W while the power input was 52.85W, this lead to a machine efficiency of 80%.

➤ Peeling Efficiency (P_E)

The Peeling efficiency (P_E) can be estimated after fabrication of the machine as the ratio of the mass of cassava to be peeled, M_{TP} in a batch in unit time to the mass fraction in grams of the peeled cassava, M_{pl} expressed in percentage according to Abdulkadir, 2012.

$$P_E = \frac{M_{TP}}{M_{pl}} \times 100\%$$

➤ Cost of machine design and fabrication

The cost of design and fabrication of a modernized cassava peeling machine was low as shown in the bill of Engineering measurement and evaluation (BEME). The unit cost of design and fabrication of 1 unit modernized cassava peeling machine as shown in Fig.3.1 is ₹ 148,620.00. This can encourage local fabrication of the machine by the welders in African region using the design made in this paper.

V. CONCLUSION AND RECOMMENDATIONS

➤ Conclusion

The conclusion of this project, the design of modernized cassava peeling machine was designed successfully. The estimated efficiency of the machine is high compared to the already existing ones. This design has lower power consumption compared to others by other researchers hence; the machine will be welcome by industries given its performance, affordability and simplicity. The varying shapes of the tuber, will not affect the performance of the machine as it was put into consideration in the design.

➤ Recommendations

The following recommendations are made on the design of a modernized cassava peeling machine:

- Greater attention should be given to the abrasive peeling process and other methods in future researches especially on cassava, potatoes, yam processing using improved machine technology.
- It is recommended that further research should be carried on the cassava tuber and barks thickness geometry effects on cassava peeling process and analysed using appropriate simulation software. This will help in generation of data for improved machine peeling operation.

- iii. Machine for peeling of cassava has the potential to drive increased cultivation and generate export products. Commercial production of this machine should be encouraged by the government of nations in Africa where this crop is grown.
- iv. Modeling of the cassava peeling process should be studied taking into consideration the physical parameters. This will go a long way in identifying any flaw that needs improvement in the present design.
- v. Mechanization of the cassava peeling process should be aimed at small, medium and large scale operation in Nigeria and other parts of African countries.
- vi. More research should be carried on the utilization of alternative sources of energy like solar to power the machine at a minimal energy cost.
- vii. Findings should be carried out on utilization of the peeled cassava bark for biogas production which can be re-used as source of energy.

REFERENCES

- [1]. Ajibola, W.A., Babarinde, F. (2016), Design and Fabrication of a Cassava Peeling Machine, International Journal of Engineering Trends and Technology (IJETT), Volume 42, Number-2, ISSN: 2231-5381, Page 60, December 2016
- [2]. <http://www.ijettjournal.org>.
- [3]. Alhassan E.A., Ijabo O.J., Afolabi E.O. (2018), Development of Cassava Peeling Machine Using An Abrasive Mechanism, Journal of Production Engineers, JPE (2018) Vol. 21 (1), 16, 2018.
- [4]. Abdulkadir B.H., (2012), Design and Fabrication of a Cassava peeling Machine, IOSR Journal of Engineering (IOSRJEN), 2 (6): 01-08-2012.
- [5]. Igbeka J.C., (1985), Mechanization of tuber (Cassava) Peeling, the PRODA cassava nibbling machine, PRODA Technical Reports No.1, pp 45-60.
- [6]. Khurmi R. S and Gupta J. K. (2008), A textbook of machine design, Eurasia publishing House (PVT) LTD, New Delhi, 2008.
- [7]. Odighoh E.U., (1983), Cassava Production, Processing and Utilization, processing and utilization, In Chan Jr., H.T. (Ed.), Handbook of Tropical Foods. Marcel Dekker, Inc., 145-200, 1983.