

# Investigation of Thermal Performance And Energy Savings In Solar Water Heaters

Dr. Nimesh Gajjar

Assistant Professor, Mechanical Engineering Department  
Gandhinagar Institute of Technology  
Gandhinagar, Gujarat

**Abstract:-** This abstract provides a quick review of the points made about solar water heater parts. In order to effectively use solar energy for water heating, it is necessary to have a steel frame, collection box frame, insulation, heat exchanger pipes, absorber plate, and glass surfaces. While existing designs have been functional, there is room for improvement, particularly in the areas of material choice, insulation technology, and heat exchanger pipe design. Energy conversion efficiency and environmental effect have both benefited from improvements in these areas.

**Keywords:-** Solar Water Heaters, Solidworks, Collector, Insulation, Absorber Plate, Heat Exchanger, Glazing Surface.

## I. INTRODUCTION

### A. Background

In the modern world of technology, solar water heaters use the sun's rays to heat water, making it a greener alternative to conventional boilers. From the geographical point of view, it has been seen that southern Europe receives more solar irradiation than the northern parts of the continent throughout the year due to the region's geography. Typical yearly sunlight hours in southern European nations such as Spain and Italy have been between 5.6 and 7.4 [21]. In certain regions, solar water heaters have been now a practical option for reducing carbon emissions and cutting down on energy use. Heat is produced using solar energy for residential and industrial purposes. Solar water heaters provide an attractive option for environmentally conscious individuals and businesses in Europe's sunniest areas because of their interconnectedness with local weather patterns, energy costs, and legislative incentives. The average annual solar radiation in sunny regions is more than 2,000 kWh per square meter [22]. Therefore, solar water heating becomes an attractive option from financial and ecological viewpoints. Government subsidies and rebates have also been instrumental in encouraging wider use of this technology, which has contributed greatly to its total growth.

### B. Problem Statement

It has been seen that solar water heaters have many benefits, but their usage is still restricted throughout Europe, especially in the United Kingdom. Only around 10% of households in southern European countries use solar water heaters, according to current statistics. This number indicates that this environmentally friendly technology is not being

used nearly as it has been. Only 15% of households in the Sunbelt use solar water heaters, according to the latest statistics on water heating methods. An illustration of the wasted potential for energy savings due to the underutilization of energy-efficient technologies is shown. High entry costs and a lack of consumer awareness have been two major roadblocks to adoption. In addition, customers have been dissatisfied due to an inconsistent supply of hot water if they live in a region of Europe where sunlight is seldom. The necessity for studies to improve the thermal efficiency of solar water heaters and assess their long-term advantages in terms of energy saving is made all the more pressing by these issues.

### C. Aim and Objectives

#### ➤ Aim

The aim of this research is to optimize the thermal performance and energy savings of solar water heaters designed and analyzed using SOLIDWORKS.

#### ➤ Objectives

- To conduct a comprehensive review of existing solar water heater designs and their thermal performance characteristics.
- To develop and simulate innovative design modifications in SOLIDWORKS aimed at enhancing the thermal efficiency of solar water heaters.
- To analyze the economic feasibility of implementing these design modifications by assessing the potential energy savings and return on investment.
- To assess the environmental impact of the optimized solar water heater systems, considering reductions in greenhouse gas emissions and overall sustainability.

### D. Research Questions

- What are the thermal performance characteristics of existing solar water heater designs?
- What design modifications can be introduced to enhance the thermal efficiency of solar water heaters when utilizing SOLIDWORKS for simulation and analysis?
- What is the economic feasibility of implementing these design modifications in terms of potential energy savings, payback period, and return on investment for end-users?
- How do the optimized solar water heater systems impact greenhouse gas emissions and contribute to overall environmental sustainability compared to traditional water heating methods?

### E. Rationale

The current research has laid the groundwork for understanding the potential of solar water heaters, but it is essential to do more studies in this field. Recent studies have shown the existence of several difficulties, such as low acceptance rates and inconsistent performance, highlighting the need to efficiently address these issues. Existing data shows that solar water heater use is not achieving its full potential, which provides a rationale for performing this research. There has been an attempt by academics to bridge the gap between abstract ideas and concrete implementations. A comprehensive investigation of solar water heaters' thermal performance and potential energy savings in Sunbelt states is, however, still lacking. This research adds to what is already known about solar water heaters and sheds light on how they have been made more efficient and less harmful to the environment.

### F. Summary

The increased interest in solar water heaters has been attributed to the international focus on environmental sustainability and the rising need for renewable energy sources. In sun-drenched European countries such as Spain and Italy, where annual solar radiation levels exceed 2,000 kWh per square meter, solar water heaters offer an eco-friendly alternative. On the other hand, only around 10% of households in the countries of southern Europe have adopted this technology. Significant upfront costs, a lack of common knowledge and comprehension, and inconsistent and unpredictable performance all work against the widespread use of this technology. This research aims to improve the effectiveness of SOLIDWORKS-created solar water heaters by reviewing existing designs, making suggestions for improvements, calculating costs, and assessing environmental impacts. With the ultimate objective of enhancing energy efficiency and encouraging sustainability, this study seeks to fill in considerable gaps in the literature on solar water heaters.

## II. LITERATURE REVIEW

### A. Introduction

The literature review in this study analyses the flexible parts of solar water heater technology and the ways in which they have been enhanced. Sustainable water heating is the focus of this publication, which summarizes studies of various materials, designs, and efficiency measures. The purpose of this research is to provide a comprehensive overview of the existing body of data and to pinpoint areas for improvement in order to enhance efficiency and reduce the environmental impact of solar water heaters.

### B. Component Design and Optimization

There has been a lot of interest in solar water heating systems recently because of their potential as environmentally friendly methods of providing hot water. In an effort to improve component performance and cost-effectiveness, researchers have investigated a wide range of design and optimization options. Using a case study, [1] emphasized the significance of efficient component design for real-world applications by discussing the design,

optimization, and economic feasibility of an industrial low-temperature hot water production system in Algeria. The effect of glazing materials on system efficiency was the focus of [2]'s in-depth study of solar water heating systems using low-density polyethylene glazing. These researches show how critical it is to carefully plan out each component and choose the right materials if you want your solar water heater to be effective and practical.

### C. Heat Storage and Transfer

The widespread use of solar water heating systems may be directly attributed to advancements in heat storage and transmission technology. The latest research on phase-change materials (PCMs) for storing thermal energy in buildings was summarized in [3]. The need to use PCMs in solar water heaters to provide a steady supply of hot water was emphasized. The necessity of effective heat transmission between the collector components and heat exchangers was highlighted in [4], which investigated the viability of hybrid photovoltaic-thermal systems for industrial and construction applications. Optimizing energy conversion in solar water heating systems is a focus of this research [49], highlighting the need to use cutting-edge materials and heat transfer processes.

Various literature studies were analyzed for heat spreader devices such as [52, 53, 54, 55] Anand Patel et al. hybrid combination of solar heater and heat exchanger & solar heater & hybrid electric car; [56-66] Patel Anand et al. for solar air heater and solar water heater; [67, 68, 69, 70, 71] Anand Patel et al. for heat exchanger where various geometrical component and materials are varied to enhance the heat transfer efficiency by performing thermal performance analysis. It is helpful for the optimization of component design in solar water heaters in the current study.

### D. Environmental Impact and Regional Considerations

The environmental impact of solar water heaters and their adaptability to different regions have been crucial considerations in their widespread adoption. [5] Evaluated the performance of an air-type photovoltaic-thermal collector combined with transverse triangle obstacles, focusing on its potential for reducing energy consumption and environmental impact. [6] Conducted a dynamic simulation and ranking analysis of using flat plate solar water heaters in the USA, highlighting the importance of region-specific assessments for solar water heater applications. These studies stress the significance of tailoring solar water heater systems to local environmental conditions and the need for sustainable energy solutions [24].

### E. Literature gap

There have been a lot of big holes in our understanding of solar water heaters that need to be filled. In order to begin, it's important to recognize that high-tech materials have the ability to boost the performance of systems [50]. This includes selective coatings and effective absorber plate materials. However, there is a big information vacuum on how to incorporate them into current systems, especially about their long-term viability and cost-effectiveness. In addition, there is a dearth of studies into dynamic modeling

and control systems that can correctly imitate real-world settings since so much attention is paid to static performance evaluations [7]. This disconnect makes it difficult to offer a more precise assessment of system efficacy in the face of changing solar radiation and water demand. More research is needed to determine the best way to optimize the pipe design of a heat exchanger, taking into consideration a variety of designs, flow rates, and materials [25]. Adopting solar water heaters also has policy and regional adaptation consequences that must be taken into account. This is an area that has not been studied enough, and more work needs to be done to understand the economic and regulatory factors that affect the widespread adoption of solar water heaters [8]. There hasn't been enough research on the potential for solar water heaters to work in tandem with other renewable energy sources such as PV or wind power. There is also a clear information gap when it comes to gauging the effectiveness of a system over time and determining what kind of upkeep is needed [9]. Equally crucial to the advancement of sustainability and the widespread use of solar water heaters is the understanding of consumer behavior and awareness components, as well as the execution of extensive environmental life cycle assessments. Solving these research gaps has a significant impact on improving the efficiency, cost-effectiveness, and ecological repercussions of solar water heater systems, bringing them into harmony with global sustainability objectives [20].

#### F. Summary

The present corpus of research on solar water heater systems is expanding constantly, with a key focus on increasing their efficiency, durability, and flexibility across a wide range of settings. Research into modern materials, dynamic models, and control systems has been extensive [19]. In order to assess long-term performance, optimize component designs, and solve regional adoption challenges, however, there are still gaps that need to be addressed. More research on customer behavior and the complementary benefits of renewable energy sources is necessary. Closing these knowledge gaps would be a huge boon to the movement towards sustainability and the widespread adoption of solar water heaters, both of which have been crucial steps towards a more energy-efficient and environmentally sensitive future.

### III. METHODOLOGY

#### A. Research Philosophy

In order to fully explore the multifaceted field of solar water heater systems, this research makes use of an interpretive philosophical framework. Based on the assumption that understanding is context-dependent and molded by social processes, interpretivism places a premium on the investigation of subjective experiences and the weight given to first-person accounts. User viewpoints, societal perspectives, and contextual complexities have been some of the other difficult features of solar water heating systems [17]. The complexity of these challenges is recognized and addressed by interpretivism, which provides a theoretical framework for the motivations, values, and perspectives of key actors. Using an interpretive methodology, this study

dives into the deeper implications of solar water heating system design decisions, performance evaluations, and decision-making processes.

#### B. Research Design

The current investigation is a descriptive study that makes use of deductive methods. This unified strategy seeks to test the validity of certain assumptions derived from established norms in the solar water heating business through empirical analysis [16]. The descriptive research technique allows for a well-structured and thorough exploration of solar water heater systems' features, components, and efficiency metrics.

#### C. Research Approach

The deductive method uses existing ideas to validate or challenge common hypotheses and assumptions. It's a fantastic descriptive research supplement for several reasons. The descriptive design gives an in-depth grasp of the issue and sets the foundation for additional study. Also, the logical methodology makes it simpler to construct testable hypotheses that organize meticulous and organized research [10]. This strategy lends legitimacy to the research and ensures data accuracy. This method improves our knowledge of solar water heater systems by empirically examining topics based on well-established theoretical frameworks.

#### D. Research Strategy

In order to learn all there is to know about solar water heaters, the study primarily uses an exploratory research approach. This approach allows for a thorough investigation of the topic, which has led to the discovery of new insights, the identification of emerging patterns, and the recognition of emerging trends that have been missed by previous models. Design parameters, performance indicators, and environmental elements all have a role in the operation of a solar water heating system [18]. The exploratory approach works well for conducting a neutral study of these complex connections. Due to its dynamic character, distinguished by continual advances and developing technologies, the area of renewable energy places a premium on exploratory research. Finding new patterns and trends through this kind of investigation is crucial for keeping the study up-to-date and useful.

#### E. Data Collection

Secondary data, collected from reliable and well-known places such as scholarly works, company reports, technical journals, and the internet, is essential to the study's success. In-depth knowledge about solar water heater system design and performance qualities is provided by this method, which justifies its use [11]. This research uses credible sources to expand on existing information and industry trends, with the goal of conducting in-depth analyses of a broad variety of system architectures, efficiency enhancements, and technological advances. This approach ensures a solid foundation for analysis and the production of useful insights while optimizing the use of time and money spent on research.

**F. Data analysis**

In order to draw conclusions, data analysts must consult a wide range of reliable resources, including scholarly articles, company annual reports, and technical manuals. By methodically examining and fusing together several sources, this technique provides a full understanding of the design and performance elements of solar water heater equipment [48]. The major purpose of this research was to develop important new understandings and make important new contributions to the current body of literature. The collected data undergo a thorough examination to reveal any hidden relationships or gaps in knowledge [12]. This study adds to the growing body of information about solar water heating systems by analyzing commonplace observations and uncovering novel tendencies.

**G. Tools and Technologies**

In the domain of three-dimensional modeling, simulation, and analysis, SOLIDWORKS software plays a pivotal role. Using this software, complex features of solar water heater designs have been visualized and analyzed in great detail [13]. The combination of theoretical robustness and practical practicality has been ensured by incorporating engineering design principles into the process of constructing innovative cooling tower topologies. SOLIDWORKS software, when combined with engineering design concepts, speeds up the prototyping and simulation processes that bridge the gap between concept and production [14].

**H. Software Feasibility**

Findings Have been derived from a variety of authoritative sources, such as scholarly works, business reports, and technical documents, as part of the data analysis technique used in this research. By methodically examining and fusing together several sources, the current technique provides a comprehensive understanding of the design and performance elements of solar water heater equipment[15]. This research aims to provide a substantial addition to the current literature by identifying important patterns, trends, and gaps in our understanding of the collected data. This investigation adds to the growth of understanding of solar water heating systems through the analysis of previously reported results and the identification of novel patterns [51].

**IV. RESULTS AND DISCUSSION**

**A. Modelling and Design**

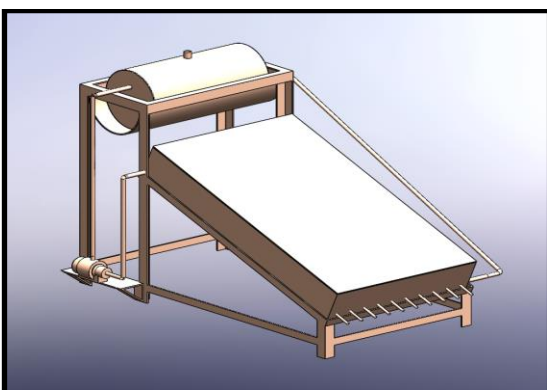

Fig 1: 3D view of solar water heater

The above diagram shows the three-dimensional view of the solar water heater that has been created in SolidWorks.

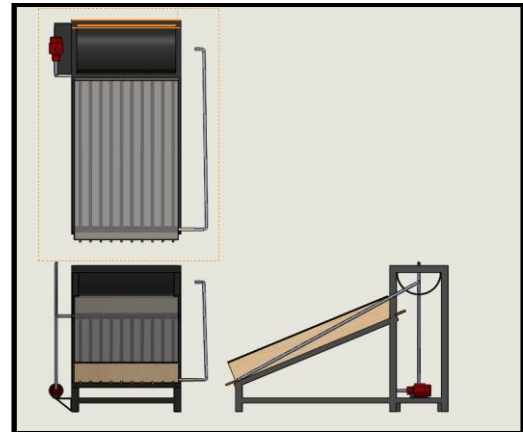

Fig 2: Orthographic of solar water heater

The above image shows the Orthographic view of the solar water heater that has been created in Solidworks. It shows the three faces from each of its sides.

➤ **Steel Frame**

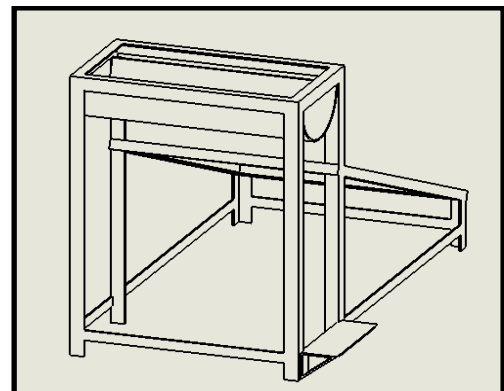

Fig 3: Steel frame of solar water heater

The steel framework supports the solar water heater. Structural support and assembly stability are its main functions [47]. The collection components are made of corrosion-resistant stainless steel or galvanized steel. This building style ensures collection components are securely held [26]. The frame is crucial to installing the collecting box, insulation, and glass.

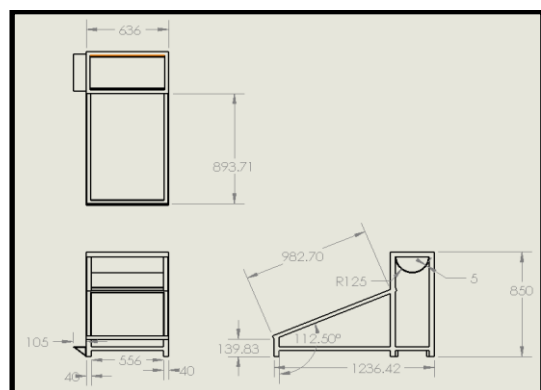

Fig 4: Dimensions of the Steel frame of the solar water heater

The mounting mechanism is responsible for firmly affixing the collector box in a manner that ensures optimal positioning for capturing sunlight [28]. The structural integrity of the steel frame guarantees the sustained stability of the complete assembly, even when subjected to unfavorable weather conditions, such as high wind velocities or substantial snow accumulation [27].

➤ *Collector box frame*

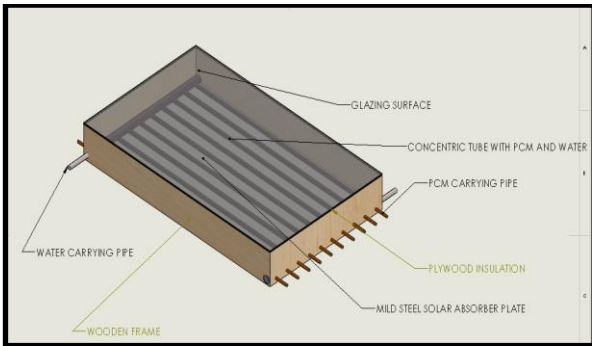

Fig 5: Collector box of solar water heater

The collector box frame is a vital part of the solar water heating system since it encloses and protects the system's vital components. Maximizing heat collection efficiency relies heavily on the system's design. Metals such as aluminum and steel have been used in their construction. The absorber plate, glass surfaces, and insulation all fit inside the collecting box's frame, producing a sealed chamber that lets in light but keeps heat in. It is crucial that the frame be tightly sealed to prevent any air leakage in order to keep the system at the right temperature [30]. With the help of the collector box frame, an enclosed chamber can be built, which increases the efficiency of heat collection. Aluminum or steel, which strikes a good mix between strength and lightweight, have been utilized in construction. The absorber plate and insulation have been protected from the elements inside the enclosure, and heat loss is minimized thanks to the enclosure's tight seal [29]. It is crucial that the collecting box frame be well sealed to prevent air leakage and keep the inside temperature stable. The collection box's metal framework aids in preventing heat from escaping. This enclosure is essential for keeping the system at a constant temperature and, by extension, increasing the effectiveness of the energy conversion process [46].

➤ *Plywood Insulation*

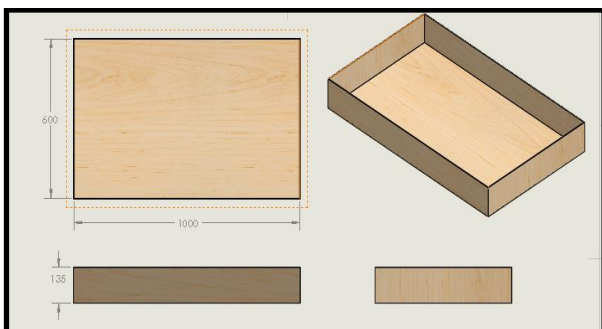

Fig 6: Plywood insulation of solar water heater

In order to keep the solar water heater as efficient as possible and reduce heat loss, plywood insulation is used. It is strategically placed within the collection box's frame to prevent heat loss and keep the energy produced by the absorber plate. Foam or fiberglass have been used because of their high heat resistance. If insulation has been done correctly, the system continues to function normally regardless of the outside temperature. Plywood insulation prevents heat from escaping and improves energy efficiency by acting as a thermal barrier [31]. The collecting box's structure is well insulated with foam or fiberglass. The insulation keeps the heat that the absorber plate generates within where it belongs, where it can do useful work, rather than letting it escape into the air. Insulation prevents temperature swings, which means that hot water output remains constant regardless of environmental factors [32].

➤ *Heat exchanger pipe design*

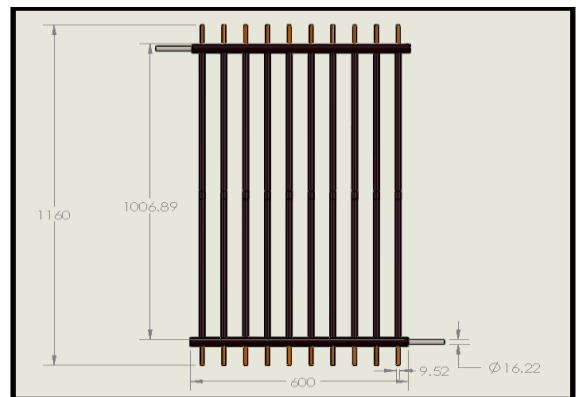

Fig 7: Heat exchanger pipe design of solar water heater

For the collected heat to be used to warm the water, the design of the heat exchanger pipes is crucial. This part is made up of a network of pipes or tubes that carry a heat-transfer fluid, the glycol-water combination, throughout the system [33]. The solar radiation warms these pipes, which run either through or beside the absorber plate. The heated fluid in the pipes is pushed to the water tank, where it transfers its heat to the water.

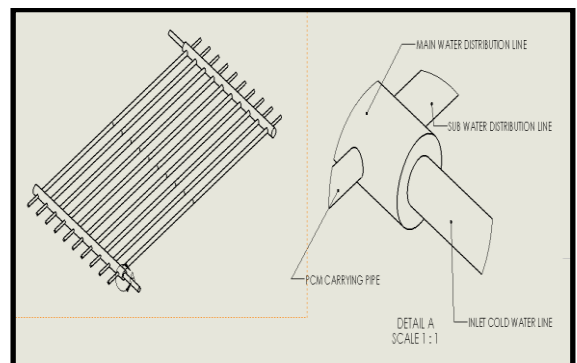

Fig 8: Fittings design of solar water heater

The efficient transfer of heat and the preservation of the proper water temperature rely heavily on the ideal construction of these pipes. Heat exchanger pipes have been installed between the collector and the water supply to facilitate the transmission of heat [34]. In order to maximize

contact with the absorber plate, the layout of these pipes is generally typified by a serpentine or coiled shape. To aid heat absorption from the absorber plate, the heat transfer fluid, a mixture of glycol and water, is pumped inside the pipes [35]. The mechanism of the pump helps to transfer heat from the fluid to the water storage tank, which raises the water's temperature. The critical design and layout of these pipes determine the efficacy of heat transfer and the maintenance of the desired water temperature.

➤ *Absorber plate*

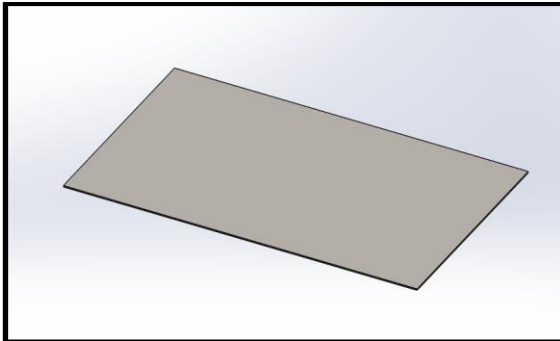

Fig 9: Absorber plate of solar water heater

The absorber plate plays a crucial role in the solar water heater system by soaking up the sun's rays. Usually, it is constructed from a thermally conductive material such as copper or aluminum and coated selectively to increase sun absorption and minimize heat loss. Sunlight is captured through an absorber plate set within a collector box. It collects solar heat, which is then transported through heat exchanger pipes and used to warm up the building's water supply [37]. The absorber plate is the vital component of a solar water heater, absorbing solar energy and transforming it into usable heat. Most solar collectors have been fabricated from thermally conductive metals such as copper or aluminum and coated with a selective substance to maximize sun absorption while reducing heat loss. The absorber plate is placed immediately beneath the glass surfaces, where it receives direct sunlight and so collects solar energy [39]. Water is heated when the absorber plate is warmed by the sun's rays and that heat is then transferred through the heat exchanger pipes. The effectiveness of a solar water heater depends heavily on the design and coating of the absorber plate.

➤ *Glazing surfaces*

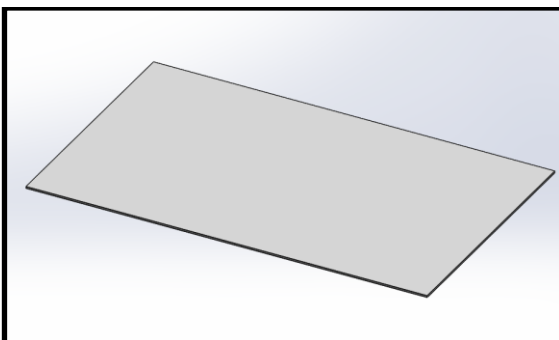

Fig 9: Glazing surface of solar water heater

The glazing surfaces shield the collector's components from damage while yet letting light in. These facades have been fabricated from tempered glass or acrylic materials that have been weather-resistant and hermetic [36]. To keep the collection box clean and dry, dust and moisture have been kept out by the glazing. It improves the collector's thermal efficiency by increasing the greenhouse effect inside it. Glazing surfaces serve as protective coverings for the collector's components while letting light through. Tempered glass or acrylic has been used because of their strength and transparency. The collecting box is protected from dirt, dust, and moisture thanks to the airtight seal provided by the glass surfaces[38]. Glazing surfaces increase the greenhouse effect, which improves thermal efficiency by permitting sunlight into the collector while keeping heat inside. These coatings protect the system's components from wear and tear caused by the elements, keeping the system running smoothly and efficiently.

*B. Discussion*

The discussion of the solar water heater system's components and their functions reveals the intricate interplay that enables efficient solar energy utilization for water heating. Understanding these elements sheds light on both the system's strengths and areas for potential improvement. The steel frame serves as the system's backbone, providing structural stability and support for various components [40]. Its robust construction ensures the system's durability, even under challenging environmental conditions. However, there's room for optimization in terms of material selection and design to reduce weight and material costs while maintaining structural integrity. The collector box frame plays a pivotal role in maximizing heat collection efficiency. Constructed from durable materials such as aluminum or steel, it encloses and protects critical components, maintaining an airtight seal to prevent heat loss [45]. To enhance its performance further, the design could incorporate advanced insulating materials or innovative sealing techniques to minimize air leakage. Plywood insulation, though effective in preventing heat loss, could benefit from ongoing advancements in insulation technology [41]. More efficient insulating materials or improved placement strategies within the collector box frame can lead to increased thermal performance and reduced energy waste. The heat exchanger pipe design is vital for transferring thermal energy efficiently from the collector to the water supply. While the coiled configuration maximizes contact with the absorber plate, ongoing research could explore alternative pipe designs or heat transfer fluids to enhance overall system efficiency. The absorber plate, composed of thermally conductive materials with selective coatings, forms the core of the system. Its efficiency significantly impacts overall performance[42]. Advancements in material science and coating technologies hold the potential for further improving heat absorption and minimizing heat loss, ultimately increasing the system's energy conversion efficiency. The glazing surfaces, made of tempered glass or acrylic, provide protection and enhance thermal performance. To continue optimizing this component, researchers have been exploring materials with improved optical properties or self-cleaning features to ensure consistent sunlight penetration and reduced

maintenance requirements. The collective efficiency of these components contributes to the system's overall effectiveness in harnessing solar energy[43]. Solar water heaters play a crucial role in reducing energy consumption and greenhouse gas emissions, particularly in regions with abundant sunlight, such as Europe. However, ongoing research and development efforts have been essential to further enhance the system's performance, increase cost-effectiveness, and promote wider adoption [44]. Moreover, the discussion underscores the importance of considering regional factors, including climate conditions and government incentives, when designing and implementing solar water heater systems. Tailoring system configurations to specific geographic regions can optimize energy savings and environmental benefits.

## V. FUTURE WORK

There is a vast amount of room for growth in the study of solar water heaters, particularly as it relates to thermal performance and energy saving. High-efficiency coatings and phase-change materials have been two examples of cutting-edge technologies that the academic community is well-positioned to study. Researchers have been also considering how to create smart control systems that make use of machine learning and the IoT. Renewable energy storage innovations and hybrid systems that use several renewable energy sources have been also researched. Furthermore, academics have been doing comprehensive life cycle analyses. In addition, this research has been centered on how its results have been used in different climates throughout the globe. Exploring these lines of inquiry has the potential to enhance the efficiency and widespread adoption of solar water heaters, thereby significantly contributing to the development of sustainable energy solutions and global environmental mitigation efforts. Sustainable energy solutions have benefited greatly from future studies into the areas of thermal performance and energy saving in solar water heaters. The continued advancement of technology and rising public awareness of environmental issues have had a significant impact on lowering energy use and slowing the rate of climate change.

## VI. CONCLUSION

In the final analysis, a solar water heater system's steel frame, collector box frame, plywood insulation, heat exchanger pipe design, absorber plate, and glass surfaces work together to efficiently and effectively heat water using solar radiation. The collector box structure maximizes heat collection efficiency and preserves temperature constancy, while the steel frame guarantees structural stability and solid support for important components. Plywood insulation prevents unnecessary heat loss, leading to a consistent supply of hot water. The heat exchanger pipe layout does a good job of conveying the collected heat to the water supply. Protection and improved thermal performance have been provided by glazing surfaces, while the absorber plate makes use of the sun's heat to increase system efficiency. In order to reduce energy consumption and greenhouse gas emissions, especially in sun-rich regions such as Europe, these components convert sunlight into a sustainable and environmentally friendly

source of hot water, with future technological advancements promising even greater sustainability and efficiency.

## REFERENCES

- [1] K. Kaci et al, "Design, optimization and economic viability of an industrial low temperature hot water production system in Algeria: A case study," *International Journal of Renewable Energy Development*, vol. 12, (3), pp. 448-458, 2023. Available: <https://www.proquest.com/scholarly-journals/design-optimization-economic-viability-industrial/docview/2830121476/se-2>. DOI: <https://doi.org/10.14710/ijred.2023.49759>.
- [2] B. Duraivel et al, "Extensive Analysis of a Reinvigorated Solar Water Heating System Using Low-Density Polyethylene Glazing," *Energies*, vol. 16, (16), pp. 5902, 2023. Available: <https://www.proquest.com/scholarly-journals/extensive-analysis-reinvigorated-solar-water/docview/2857024441/se-2>. DOI: <https://doi.org/10.3390/en16165902>.
- [3] F. L. Rashid et al, "A Review of Recent Improvements, Developments, and Effects of Using Phase-Change Materials in Buildings to Store Thermal Energy," *Designs*, vol. 7, (4), pp. 90, 2023. Available: <https://www.proquest.com/scholarly-journals/review-recent-improvements-developments-effects/docview/2856983241/se-2>. DOI: <https://doi.org/10.3390/designs7040090>.
- [4] M. Samykano, "Hybrid Photovoltaic Thermal Systems: Present and Future Feasibilities for Industrial and Building Applications," *Buildings*, vol. 13, (8), pp. 1950, 2023. Available: <https://www.proquest.com/scholarly-journals/hybrid-photovoltaic-thermal-systems-present/docview/2856971387/se-2>. DOI: <https://doi.org/10.3390/buildings13081950>.
- [5] H. Choi and K. Choi, "Performance Evaluation of the Air-Type Photovoltaic-Thermal Collector Combined with Transverse Triangle Obstacle," *Int. J. Energy Res.*, vol. 2023, 2023. Available: <https://www.proquest.com/scholarly-journals/performance-evaluation-air-type-photovoltaic/docview/2853673997/se-2>. DOI: <https://doi.org/10.1155/2023/4936477>.
- [6] M. J. Daryosh et al, "Energy-Environmental One-Year Dynamic Simulation and Ranking Analysis of Using Flat Plate Solar Water Heater to Supply the Heating Demand of an Apartment in the USA: A Comprehensive Review," *International Journal of Photoenergy*, vol. 2023, 2023. Available: <https://www.proquest.com/scholarly-journals/energy-environmental-one-year-dynamic-simulation/docview/2853665828/se-2>. DOI: <https://doi.org/10.1155/2023/3323276>.
- [7] E. Ali, A. Ajbar and B. Lamrani, "Modeling and Dynamic Simulation of a Phase-Change Material Tank for Powering Chiller Generators in District Cooling Networks," *Sustainability*, vol. 15, (13), pp. 10332, 2023. Available: <https://www.proquest.com/scholarly-journals/modeling-dynamic-simulation-phase-change>

- material/docview/2836504645/se-2. DOI: <https://doi.org/10.3390/su151310332>.
- [8] Y. Zeng et al, "Research on Energy Savings of an Air-Source Heat Pump Hot Water System in a College Student's Dormitory Building," *Sustainability*, vol. 15, (13), pp. 10006, 2023. Available: <https://www.proquest.com/scholarly-journals/research-on-energy-savings-air-source-heat-pump/docview/2836496064/se-2>. DOI: <https://doi.org/10.3390/su151310006>.
- [9] A. Villarruel-Jaramillo et al, "Modeling and Performance Evaluation of Hybrid Solar Cooling Systems Driven by Photovoltaic and Solar Thermal Collectors—Case Study: Greenhouses of Andalusia," *Energies*, vol. 16, (13), pp. 4888, 2023. Available: <https://www.proquest.com/scholarly-journals/modeling-performance-evaluation-hybrid-solar/docview/2836392795/se-2>. DOI: <https://doi.org/10.3390/en16134888>.
- [10] O. K. Ahmed et al, "The Various Designs of Storage Solar Collectors: A Review," *International Journal of Renewable Energy Development*, vol. 12, (1), pp. 166-185, 2023. Available: <https://www.proquest.com/scholarly-journals/various-designs-storage-solar-collectors-review/docview/2830126515/se-2>. DOI: <https://doi.org/10.14710/ijred.2023.45969>.
- [11] P. P. Gohil et al, "Current Status and Advancement in Thermal and Membrane-Based Hybrid Seawater Desalination Technologies," *Water*, vol. 15, (12), pp. 2274, 2023. Available: <https://www.proquest.com/scholarly-journals/current-status-advancement-thermal-membrane-based/docview/2829889519/se-2>. DOI: <https://doi.org/10.3390/w15122274>.
- [12] S. Wang et al, "The Influence of Storage Tank Volume in the Nighttime Heat Dissipation and Freezing Process of All-Glass Vacuum Tube Solar Water Heaters," *Energies*, vol. 16, (12), pp. 4781, 2023. Available: <https://www.proquest.com/scholarly-journals/influence-storage-tank-volume-on-nighttime-heat/docview/2829796337/se-2>. DOI: <https://doi.org/10.3390/en16124781>.
- [13] P. Li et al, "Exergy Analysis of a Shell and Tube Energy Storage Unit with Different Inclination Angles," *Energies*, vol. 16, (11), pp. 4297, 2023. Available: <https://www.proquest.com/scholarly-journals/exergy-analysis-shell-tube-energy-storage-unit/docview/2824001707/se-2>. DOI: <https://doi.org/10.3390/en16114297>.
- [14] H. S. Mohammad et al, "Experimental and Numerical Investigation of the Effect of Water Cooling on the Temperature Distribution of Photovoltaic Modules Using Copper Pipes," *Energies*, vol. 16, (10), pp. 4102, 2023. Available: <https://www.proquest.com/scholarly-journals/experimental-numerical-investigation-effect-water/docview/2819445946/se-2>. DOI: <https://doi.org/10.3390/en16104102>.
- [15] A. Ajbar, B. Lamrani and E. Ali, "Dynamic Investigation of a Coupled Parabolic Trough Collector–Phase Change Material Tank for Solar Cooling Process in Arid Climates," *Energies*, vol. 16, (10), pp. 4235, 2023. Available: <https://www.proquest.com/scholarly-journals/dynamic-investigation-coupled-parabolic-trough/docview/2819444343/se-2>. DOI: <https://doi.org/10.3390/en16104235>.
- [16] S. K. Pathak et al, "Hot Water Generation for Domestic Use in Residential Buildings through PCM Integrated YouTube Based Solar Thermal Collector: A 4-E Analysis," *Buildings*, vol. 13, (5), pp. 1212, 2023. Available: <https://www.proquest.com/scholarly-journals/hot-water-generation-domestic-use-residential/docview/2819417994/se-2>. DOI: <https://doi.org/10.3390/buildings13051212>.
- [17] D. Zhang, Kwok-Wai Mui and L. Wong, "Establishing the Relationship between Occupants' Thermal Behavior and Energy Consumption during Showering," *Buildings*, vol. 13, (5), pp. 1300, 2023. Available: <https://www.proquest.com/scholarly-journals/establishing-relationship-between-occupants/docview/2819413566/se-2>. DOI: <https://doi.org/10.3390/buildings13051300>.
- [18] O. Younis et al, "Numerical Analysis of the Influence of Inner Tubes Arrangement on the Thermal Performance of Thermal Energy Storage Unit," *Energies*, vol. 16, (9), pp. 3663, 2023. Available: <https://www.proquest.com/scholarly-journals/numerical-analysis-influence-inner-tubes/docview/2812460746/se-2>. DOI: <https://doi.org/10.3390/en16093663>.
- [19] K. M. Hamid et al, "Numerical Evaluation of the Hydrothermal Process in a Water-Surrounded Heater of Natural Gas Pressure Reduction Plants," *Water*, vol. 15, (8), pp. 1469, 2023. Available: <https://www.proquest.com/scholarly-journals/numerical-evaluation-hydrothermal-process-water/docview/2806645558/se-2>. DOI: <https://doi.org/10.3390/w15081469>.
- [20] A. D. Tuncer et al, "Experimental Evaluation of a Photovoltaic/Thermal Air Heater with Metal Mesh-Integrated Thermal Energy Storage System," *Energies*, vol. 16, (8), pp. 3449, 2023. Available: <https://www.proquest.com/scholarly-journals/experimental-evaluation-photovoltaic-thermal-air/docview/2806531617/se-2>. DOI: <https://doi.org/10.3390/en16083449>.
- [21] T. Guo et al, "Thermal Performance and Energy Analysis of Phase Change Material-Integrated Building with the Auxiliary Heating System in Different Climate Regions," *Int. J. Energy Res.*, vol. 2023, 2023. Available: <https://www.proquest.com/scholarly-journals/thermal-performance-energy-analysis-phase-change/docview/2802484909/se-2>. DOI: <https://doi.org/10.1155/2023/2518180>.
- [22] K. Sornek et al, "A Review of Experimental and Numerical Analyses of Solar Thermal Walls," *Energies*, vol. 16, (7), pp. 3102, 2023. Available: <https://www.proquest.com/scholarly-journals/review-experimental-numerical-analyses->



- solar/docview/2799616422/se-2. DOI: <https://doi.org/10.3390/en16073102>.
- [23] J. F. Hinojosa, S. F. Moreno and V. M. has been torena, "Low-Temperature Applications of Phase Change Materials for Energy Storage: A Descriptive Review," *Energies*, vol. 16, (7), pp. 3078, 2023. Available: <https://www.proquest.com/scholarly-journals/low-temperature-applications-phase-change/docview/2799597784/se-2>. DOI: <https://doi.org/10.3390/en16073078>.
- [24] A. B. Sidi Mohammed El et al, "Experimental Performance and Cost-Effectiveness of a Combined Heating System under Saharan Climate," *Buildings*, vol. 13, (3), pp. 635, 2023. Available: <https://www.proquest.com/scholarly-journals/experimental-performance-cost-effectiveness/docview/2791600742/se-2>. DOI: <https://doi.org/10.3390/buildings13030635>.
- [25] M. S. Hossain et al, "A Comparative Investigation on Solar PVT- and PVT-PCM-Based Collector Constancy Performance," *Energies*, vol. 16, (5), pp. 2224, 2023. Available: <https://www.proquest.com/scholarly-journals/comparative-investigation-on-solar-pvt-pcm-based/docview/2785193957/se-2>. DOI: <https://doi.org/10.3390/en16052224>.
- [26] R. Rotas et al, "Adaptive Dynamic Building Envelopes with Solar Power Components: Annual Performance Assessment for Two Pilot Sites," *Energies*, vol. 16, (5), pp. 2148, 2023. Available: <https://www.proquest.com/scholarly-journals/adaptive-dynamic-building-envelopes-with-solar/docview/2785193893/se-2>. DOI: <https://doi.org/10.3390/en16052148>.
- [27] A. A. Hafiz Taimoor et al, "Recent Progress and Challenges in MXene-Based Phase Change Material for Solar and Thermal Energy Applications," *Energies*, vol. 16, (4), pp. 1977, 2023. Available: <https://www.proquest.com/scholarly-journals/recent-progress-challenges-mxene-based-phase/docview/2779543794/se-2>. DOI: <https://doi.org/10.3390/en16041977>.
- [28] N. Modi, X. Wang and M. Negnevitsky, "Solar Hot Water Systems Using Latent Heat Thermal Energy Storage: Perspectives and Challenges," *Energies*, vol. 16, (4), pp. 1969, 2023. Available: <https://www.proquest.com/scholarly-journals/solar-hot-water-systems-using-latent-heat-thermal/docview/2779489082/se-2>. DOI: <https://doi.org/10.3390/en16041969>.
- [29] S. Lv, J. Zhu and R. Wang, "Experimental Research on a Solar Energy Phase Change Heat Storage Heating System Applied in the Rural Area," *Sustainability*, vol. 15, (3), pp. 2575, 2023. Available: <https://www.proquest.com/scholarly-journals/experimental-research-on-solar-energy-phase/docview/2774986020/se-2>. DOI: <https://doi.org/10.3390/su15032575>.
- [30] W. Ye, D. Jamshideasli and J. M. Khodadadi, "Improved Performance of Latent Heat Energy Storage Systems in Response to Utilisation of High Thermal Conductivity Fins," *Energies*, vol. 16, (3), pp. 1277, 2023. Available: <https://www.proquest.com/scholarly-journals/improved-performance-latent-heat-energy-storage/docview/2774895555/se-2>. DOI: <https://doi.org/10.3390/en16031277>.
- [31] S. M. Hashemi, A. Maleki and M. H. Ahmadi, "The impact of ZrO<sub>2</sub>/SiO<sub>2</sub> and ZrO<sub>2</sub>/SiO<sub>2</sub>@PANI nanofluid on the performance of pulsating heat pipe, an experimental study," *Journal of Nanostructure in Chemistry*, vol. 12, (6), pp. 1089-1104, 2022. Available: <https://www.proquest.com/scholarly-journals/impact-zro-sub-2-sio-pani-nanofluid-on/docview/2731945922/se-2>. DOI: <https://doi.org/10.1007/s40097-021-00451-4>.
- [32] S. Nijmeh et al, "Numerical Investigation of a Solar PV/T Air Collector Under the Climatic Conditions of Zarqa, Jordan," *International Journal of Renewable Energy Development*, vol. 11, (4), pp. 963-972, 2022. Available: <https://www.proquest.com/scholarly-journals/numerical-investigation-solar-pv-t-air-collector/docview/2830126500/se-2>. DOI: <https://doi.org/10.14710/ijred.2022.45306>.
- [33] M. Khademy, A. Saraei and M. H. J. Abyaneh, "Application of trigeneration system power by concentrating photovoltaic-thermal solar collectors for energy demands of an industrial complex," *International Journal of Energy and Environmental Engineering*, vol. 13, (3), pp. 1101-1128, 2022. Available: <https://www.proquest.com/scholarly-journals/application-trigeneration-system-power/docview/2704501030/se-2>. DOI: <https://doi.org/10.1007/s40095-022-00512-6>.
- [34] S. S. Christopher and V. Kumaresan, "2E (energy and exergy) analysis of solar evacuated tube-compound parabolic concentrator with different configurations of thermal energy storage system," *Environmental Science and Pollution Research*, vol. 29, (40), pp. 61135-61147, 2022. Available: <https://www.proquest.com/scholarly-journals/2e-energy-exergy-analysis-solar-evacuated-tube/docview/2708094210/se-2>. DOI: <https://doi.org/10.1007/s11356-022-20209-x>.
- [35] N. Rasaiah et al, "Review on phase change materials for solar energy storage applications," *Environmental Science and Pollution Research*, vol. 29, (7), pp. 9491-9532, 2022. Available: <https://www.proquest.com/scholarly-journals/review-on-phase-change-materials-solar-energy/docview/2621924628/se-2>. DOI: <https://doi.org/10.1007/s11356-021-17152-8>.
- [36] A. Uniyal et al, "Recent Advancements in Evacuated Tube Solar Water Heaters: A Critical Review of the Integration of Phase Change Materials and Nanofluids with ETCs," *Energies*, vol. 15, (23), pp. 8999, 2022. Available: <https://www.proquest.com/scholarly-journals/recent-advancements-evacuated-tube-solar-water/docview/2748536141/se-2>. DOI: <https://doi.org/10.3390/en15238999>.
- [37] N. Ghazouani et al, "Solar Desalination by Humidification-Dehumidification: A Review," *Water*, vol. 14, (21), pp. 3424, 2022. Available: <https://www.proquest.com/scholarly-journals/solar->

- desalination-humidification/docview/2734752768/se-2.  
DOI: <https://doi.org/10.3390/w14213424>.
- [38] P. Sinethemba et al, "Quantification of the Impact of Solar Water Heating and Influence of Its Potential Utilisation through Strategic Campaign: Case Study in Dimbaza, South Africa," *Energies*, vol. 15, (21), pp. 8283, 2022. Available: <https://www.proquest.com/scholarly-journals/quantification-impact-solar-water-heating/docview/2734627285/se-2>. DOI: <https://doi.org/10.3390/en15218283>.
- [39] P. Sinethemba et al, "Assessing the Feasibility and the Potential of Implementing Solar Water Heaters in Dimbaza, a Township in Eastern Cape, South Africa," *Sustainability*, vol. 14, (19), pp. 12502, 2022. Available: <https://www.proquest.com/scholarly-journals/assessing-feasibility-potential-implementing/docview/2724319889/se-2>. DOI: <https://doi.org/10.3390/su141912502>.
- [40] K. Sornek and K. Papis-Frańczek, "Development and Tests of the Solar Air Heater with Thermal Energy Storage," *Energies*, vol. 15, (18), pp. 6583, 2022. Available: <https://www.proquest.com/scholarly-journals/development-tests-solar-air-heater-with-thermal/docview/2716529065/se-2>. DOI: <https://doi.org/10.3390/en15186583>.
- [41] Olinto Evaristo da Silva Júnior et al, "Solar Heating with Flat-Plate Collectors in Residential Buildings: A Review," *Energies*, vol. 15, (17), pp. 6130, 2022. Available: <https://www.proquest.com/scholarly-journals/solar-heating-with-flat-plate-collectors/docview/2711355420/se-2>. DOI: <https://doi.org/10.3390/en15176130>.
- [42] A. F. Wan et al, "Global Challenges of Current Building-Integrated Solar Water Heating Technologies and Its Prospects: A Comprehensive Review," *Energies*, vol. 15, (14), pp. 5125, 2022. Available: <https://www.proquest.com/scholarly-journals/global-challenges-current-building-integrated/docview/2694003867/se-2>. DOI: <https://doi.org/10.3390/en15145125>.
- [43] D. Huang et al, "Study on the Energy Efficiency Improvement and Operation Optimization of a Solar Water Heating System," *Applied Sciences*, vol. 12, (14), pp. 7263, 2022. Available: <https://www.proquest.com/scholarly-journals/study-on-energy-efficiency-improvement-operation/docview/2693930772/se-2>. DOI: <https://doi.org/10.3390/app12147263>.
- [44] A. A. Demiss and A. T. Eneyaw, "Long-Term Performance Analysis of Direct Photovoltaic Thermal-Assisted Heat Pump Water Heater Using Computational Model," *International Journal of Photoenergy*, vol. 2022, 2022. Available: <https://www.proquest.com/scholarly-journals/long-term-performance-analysis-direct/docview/2693596255/se-2>. DOI: <https://doi.org/10.1155/2022/2024470>.
- [45] R. K. Ali et al, "A Comparative Thermal Performance Assessment of Various Solar Collectors for Domestic Water Heating," *International Journal of Photoenergy*, vol. 2022, 2022. Available: <https://www.proquest.com/scholarly-journals/comparative-thermal-performance-assessment/docview/2680914007/se-2>. DOI: <https://doi.org/10.1155/2022/9536772>.
- [46] R. Li and G. Cui, "Comprehensive Performance Evaluation of a Dual-Function Active Solar Thermal Façade System Based on Energy, Economic and Environmental Analysis in China," *Energies*, vol. 15, (11), pp. 4147, 2022. Available: <https://www.proquest.com/scholarly-journals/comprehensive-performance-evaluation-dual/docview/2674356029/se-2>. DOI: <https://doi.org/10.3390/en15114147>.
- [47] N. Tsvetkov et al, "Hardware and Software Implementation for Solar Hot Water System in Northern Regions of Russia," *Energies*, vol. 15, (4), pp. 1446, 2022. Available: <https://www.proquest.com/scholarly-journals/hardware-software-implementation-solar-hot-water/docview/2632718396/se-2>. DOI: <https://doi.org/10.3390/en15041446>.
- [48] M. A. Fikri et al, "Experimental Determination of Water, Water/Ethylene Glycol and TiO<sub>2</sub>-SiO<sub>2</sub> Nanofluids mixture with Water/Ethylene Glycol to Three Square Multilayer Absorber Collector on Solar Water Heating System: A Comparative Investigation," *IOP Conference Series. Materials Science and Engineering*, vol. 1062, (1), 2021. Available: <https://www.proquest.com/scholarly-journals/experimental-determination-water-ethylene-glycol/docview/2513062163/se-2>. DOI: <https://doi.org/10.1088/1757-899X/1062/1/012019>.
- [49] R. Alayi et al, "Thermal and Environmental Analysis Solar Water Heater System for Residential Buildings," *International Journal of Photoenergy*, vol. 2021, 2021. Available: <https://www.proquest.com/scholarly-journals/thermal-environmental-analysis-solar-water-heater/docview/2563360572/se-2>. DOI: <https://doi.org/10.1155/2021/6838138>.
- [50] M. Beccali et al, "Solar and Heat Pump Systems for Domestic Hot Water Production on a Small Island: The Case Study of Lampedusa," *Applied Sciences*, vol. 10, (17), pp. 5968, 2020. Available: <https://www.proquest.com/scholarly-journals/solar-heat-pump-systems-domestic-hot-water/docview/2439642012/se-2>. DOI: <https://doi.org/10.3390/app10175968>.
- [51] J. Huang et al, "Solar Water Heating Systems Applied to High-Rise Buildings—Lessons from Experiences in China," *Energies*, vol. 12, (16), 2019. Available: <https://www.proquest.com/scholarly-journals/solar-water-heating-systems-applied-high-rise/docview/2317015640/se-2>. DOI: <https://doi.org/10.3390/en12163078>.
- [52] Patel, A (2023). "Comparative analysis of solar heaters and heat exchangers in residential water heating". *International Journal of Science and Research Archive (IJSRA)*,09(02), 830–843. <https://doi.org/10.30574/ijrsra.2023.9.2.0689>.
- [53] Patel, A. (2023). Enhancing Heat Transfer Efficiency in Solar Thermal Systems Using Advanced Heat Exchangers. *Multidisciplinary International Journal of Research and Development (MIJRD)*, 02(06), 31–51.

- <https://www.mijrd.com/papers/v2/i6/MIJRDV2I60003.pdf>.
- [54] Patel, Anand "Optimizing the Efficiency of Solar Heater and Heat Exchanger Integration in Hybrid System", *TIJER - International Research Journal* ([www.tijer.org](http://www.tijer.org)), ISSN:2349-9249, Vol.10, Issue 8, page no.b270-b281, August-2023, Available :<http://www.tijer.org/papers/TIJER2308157.pdf>
- [55] Patel, Anand. "SOLAR HEATER-ASSISTED ELECTRIC VEHICLE CHARGING STATIONS: A GREEN ENERGY SOLUTION." *Journal of Aeronautical Materials* (ISSN: 1005-5053), vol. 43, no. 02, 2023, pp. 520–534, [www.hkclxb.cn/article/view/2023/2-520.html](http://www.hkclxb.cn/article/view/2023/2-520.html).
- [56] Patel, A. (2023). Thermal Performance of Combine Solar Air Water Heater with Parabolic Absorber Plate. *International Journal of All Research Education and Scientific Methods (IJARESM)*, 11(7), PP: 2385–2391. [http://www.ijaresm.com/uploaded\\_files/document\\_file/Anand\\_Patel3pFZ.pdf](http://www.ijaresm.com/uploaded_files/document_file/Anand_Patel3pFZ.pdf)
- [57] Patel, Anand. "Effect of W Rib Absorber Plate on Thermal Performance Solar Air Heater." *International Journal of Research in Engineering and Science (IJRES)*, vol. 11, no. 7, July 2023, pp. 407–412. Available: <https://www.ijres.org/papers/Volume-11/Issue-7/1107407412.pdf>
- [58] Patel, Anand. "Performance Evaluation of Square Emboss Absorber Solar Water Heaters." *International Journal For Multidisciplinary Research (IJFMR)*, Volume 5, Issue 4, July-August 2023, PP 01-09. <https://doi.org/10.36948/ijfmr.2023.v05i04.4917>
- [59] Anand Patel. (2023). Thermal Performance Analysis of Wire Mesh Solar Air Heater. *Eduzone: International Peer Reviewed/Refereed Multidisciplinary Journal*, 12(2), 91–96. Retrieved from <https://www.eduzonejournal.com/index.php/eiprmj/article/view/389>
- [60] Patel, A (2023). "Thermal performance analysis conical solar water heater". *World Journal of Advanced Engineering Technology and Sciences (WJAETS)*, 9(2), 276–283. <https://doi.org/10.30574/wjaets.2023.9.2.02286>
- [61] Patel, A. (2023). INTEGRATING SOLAR HEATERS INTO RENEWABLE ENERGY SYSTEMS: A CASE STUDY. *China Petroleum Processing and Petrochemical Technology*, 23(2), 1050–1065. <http://zgysjgysyhgjs.cn/index.php/reric/article/view/2-1050.html>
- [62] Patel, A (2023). "Efficiency enhancement of solar water heaters through innovative design". *International Journal of Science and Research Archive (IJSRA)*,10(01), 289–303. <https://doi.org/10.30574/ijrsra.2023.10.1.0724>.
- [63] Anand Kishorbhai Patel, 2023. Technological Innovations in Solar Heater Materials and Manufacturing. *United International Journal for Research & Technology (UIJRT)*, 4(11), pp13-24.
- [64] Patel, Anand. "OPTIMIZING SOLAR HEATER EFFICIENCY FOR SUSTAINABLE RENEWABLE ENERGY." *CORROSION AND PROTECTION*, ISSN: 1005-748X, vol. 51, no. 2, 2023, pp. 244–258, [www.fsyfh.cn/view/article/2023/02-244.php](http://www.fsyfh.cn/view/article/2023/02-244.php).
- [65] Patel, Anand. "HEAT STORAGE STRATEGIES IN SOLAR HEATER SYSTEMS FOR NIGHTTIME USE." *NANOBIOTECHNOLOGY REPORTS* (ISSN: 2635-1676) (E-ISSN: 2635-1684), vol. 18, no. 1, Oct. 2023, pp. 49–66. [nanobiotechnologyreports.org/index.html](http://nanobiotechnologyreports.org/index.html).
- [66] Patel, Anand. "A COMPARATIVE ANALYSIS OF SOLAR HEATER TECHNOLOGIES FOR RESIDENTIAL APPLICATIONS." *JOURNAL OF AERONAUTICAL MATERIALS* (ISSN: 1005-5053), vol. 43, no. 02, Oct. 2023, pp. 633–47. [www.hkclxb.cn/article/view/2023/2-633.html](http://www.hkclxb.cn/article/view/2023/2-633.html).
- [67] Patel, Anand. "Advancements in Heat Exchanger Design for Waste Heat Recovery in Industrial Processes." *World Journal of Advanced Research and Reviews (WJARR)*, vol. 19, no. 03, Sept. 2023, pp. 137–52, doi:10.30574/wjarr.2023.19.3.1763.
- [68] Anand Patel, 2023, Heat Exchangers in Industrial Applications: Efficiency and Optimization Strategies, *INTERNATIONAL JOURNAL OF ENGINEERING RESEARCH & TECHNOLOGY (IJERT)* Volume 12, Issue 09 (September 2023), DOI : 10.17577/IJERTV12IS090003 (<https://www.ijert.org/research/heat-exchangers-in-industrial-applications-efficiency-and-optimization-strategies-IJERTV12IS090003.pdf>).
- [69] Patel, Anand. "Heat Exchanger Materials and Coatings: Innovations for Improved Heat Transfer and Durability." *International Journal of Engineering Research and Applications (IJERA)*, vol. 13, no. 9, Sept. 2023, pp. 131–42, doi:10.9790/9622-1309131142.
- [70] Patel, Anand. "EFFECT OF PITCH ON THERMAL PERFORMANCE SERPENTINE HEAT EXCHANGER." *INTERNATIONAL JOURNAL OF MECHANICAL ENGINEERING (IJRAME)*, vol. 11, no. 8, Aug. 2023, pp. 01–11. <https://doi.org/10.5281/zenodo.8225457>.
- [71] Patel, Anand "Performance Analysis of Helical Tube Heat Exchanger", *TIJER - International Research Journal* ([www.tijer.org](http://www.tijer.org)), ISSN:2349-9249, Vol.10, Issue 7, page no.946-950, July-2023, Available :<http://www.tijer.org/papers/TIJER2307213.pdf>.