

MATLAB-Based Optimisation and Control of Distributed Energy Resources in Electric Grid

Eng. Faisal Alajmi¹

¹Specialist Trainer in Public Authority for Applied Education and Training, University of Sunderland, United Kingdom.

Eng. Hadyan Ali Alajmi²

²Specialist Trainer (B) in Public Authority for Applied Education and Training, the University of Arab Academy for Science, Technology and Transport

Abstract:- This study delves into the integration of photovoltaic (PV) systems with the utility grid, comparing their performance with and without the implementation of a Fuzzy Logic Controller (FLC). The integration is facilitated through a meticulously designed DC-DC boost-converter system and a three-level bridge inverter, aiming to stabilize the boost voltage generated by the PV system.

A comparative analysis was conducted to assess the system's performance under two distinct cases: one involving the conventional controller (MPPT) and the other employing the fuzzy controller (FLC). The aim was to underscore the enhanced attributes of the fuzzy controller in effectively modulating the desired system performance.

In the first case, the PV system is integrated directly into the grid with the intervention of MPPT control method. The behavior of the system is analyzed under varying conditions, highlighting voltage oscillations and potential instability issues. In the second scenario, the PV system is integrated into the grid with the inclusion of an FLC. The FLC's adaptive and intelligent control strategy is employed to manage voltage fluctuations and maintain stable grid synchronization. The controller's performance is assessed across a spectrum of operational scenarios.

The comparison of system outcomes between the FLC and MPPT controllers clearly established the advantages of the FLC method in reducing output voltage oscillation, minimizing settling time, and enhancing stability. The FLC method not only matches the power optimization capabilities of the traditional MPPT technique but also provides superior control performance under various scenarios. This underscores the potential of fuzzy logic-based control strategies for efficient and robust control of distributed energy resources in electric grids. The findings of this study contribute to the understanding of advanced control methodologies in the context of PV integration, offering valuable guidance for the development of robust and reliable renewable energy systems.

I. INTRODUCTION

Renewable Energy Sources (RES) refer to forms of energy derived from naturally replenishing resources that are practically limitless [1]. In contrast to finite & environmentally damaging fossil fuels, RES offer a cleaner & more sustainable alternative for fulfilling our energy requirements [2]. RES cover a broad spectrum of resources and tools, such as geothermal energy, wind energy, solar

energy, and others. [3]. Distributed Energy Resources (DER) have emerged as a crucial element of today's Electric Grids (EG) in the past few decades primarily to a surge in the adoption of RESs and the rising need for decentralized power generation [4]. DERs provide multiple benefits, notably increased grid resilience, decreased emission of greenhouse gasses, and better efficiency of energy. Instances of DERs involve solar panels, small hydropower generators, and energy storage devices. Since these resources are often located near the places where energy is consumed and have connection to the local distribution system, localized power generation and increased energy efficiency are made feasible. [5].

A key advantage of RES & DER is their role in reducing harmful emissions & mitigate climate change. By harnessing RES, the dependence on finite fossil fuels can be diminished, contributing to a more sustainable & low-carbon energy system. Furthermore, RES & DER facilitate decentralised power generation, fostering greater energy independence & resilience [6]. The deployment of RES & DER has experienced substantial growth, propelled by technological advancements, cost reductions, & supportive policies & incentives. Consequently, renewable energy has become an increasingly significant component of the global energy mix, with numerous countries setting ambitious targets to expand their RES & DER capacity. While RES & DER offer numerous advantages, their widespread adoption still encounters certain challenges. These include addressing the intermittency & variability of certain RES, finding effective energy storage solutions, resolving grid integration issues, & overcoming investment barriers. However, ongoing research & development efforts continue to enhance RES & DER technologies & address these challenges to ensure their effective integration into the energy landscape [7].

The aim of this paper is to simulate and evaluate the integration of PV arrays integrated with the grid utilising MATLAB's Simulink. The main objectives are to compare the performance of Incremental Conductance Control and Fuzzy Logic Control (FLC) methods in maximizing energy production from a distributed energy resource (DER) containing of a PV scheme linked to the utility grid. This includes developing a mathematical model of the DER scheme, evaluating characteristics of PV cells, applying and assessing the Incremental Conductance Technique for MPPT, and designing a FLC to optimize the scheme's performance. The project also aims to investigate the stability, response time, and robustness of the FLC-controlled system in different environmental situations and compare the results with those obtained utilising the Incremental Conductance

algorithm. Through this investigation, the paper seeks to contribute to the improvement of renewable energy management and the PV arrays efficient integration with the utility grid.

II. LITERATURE REVIEW

In recent times, the integration & efficient operation of DER in modern EGs has become increasingly important. To overcome the challenges associated with managing & coordinating DER, experts have turned to advanced optimisation & control techniques. MATLAB has gained significant popularity as a powerful tool for this purpose. Accurately modelling & simulating DER technologies plays a crucial role in understanding their behaviour, performance, & impact on the EG. These accurate models enable the evaluation of DER performance under diverse conditions, facilitating optimisation of their operation & maximising their potential benefits. Furthermore, accurate modelling helps identify challenges related to voltage regulation, power quality, & grid stability, thus ensuring seamless integration of DER into the existing grid infrastructure. Developing optimisation algorithms & control strategies based on accurate models is essential for effectively managing DER systems, enabling optimal dispatch, resource allocation, & real-time adjustments.

A. Distributed Energy Resources (DER) & Grid Integration

DERs encompass a diverse array of decentralised power generation & storage technologies located near energy consumption points. Unlike traditional centralised generation, DERs may work autonomously of the primary utility grid or in conjunction with it, contributing to improved energy efficiency, reliability, and sustainability. There are various types of DERs:

- Solar Photovoltaic (PV) Systems: Converting sunlight immediately into electricity and find widespread use in residential, commercial, and industrial settings.
- Wind Turbines: Harnessing kinetic energy from the wind, they convert it into electrical energy and can be situated onshore or offshore.
- Battery Energy Storage Systems (BESS): Storing electrical energy for later use, BESS enables load balancing and energy management while providing power during peak demand or grid disruptions.
- Combined Heat & Power Systems: Generating both electricity & heat concurrently, these systems utilise waste heat for heating/cooling purposes, maximising overall efficiency.
- Microgrids: Functioning as small-scale, autonomous energy systems, microgrids can operate independently or be interconnected with the main grid, integrating multiple DERs for localised energy management.
- Fuel Cells: Through an electrochemical process using hydrogen or other fuels, fuel cells produce electricity, particularly suitable where a stable fuel supply is available.
- Biomass Energy Systems: Utilising organic materials like agricultural residues & wood waste, biomass systems generate electricity, promoting renewable energy utilisation.

- Geothermal Energy Systems: Tapping into heat from the Earth's crust, these systems produce electricity or offer direct heating and cooling applications in areas with significant geothermal resources.
- Small-Scale Hydroelectric Power: Leveraging flowing water in rivers or streams, small hydroelectric systems generate electricity while remaining environmentally friendly.

As the integration of DERs into EGs grows, optimising & effectively controlling their operation poses both opportunities & challenges in achieving a sustainable & resilient energy landscape.

➤ *The Importance of DER*

DER integration in EG holds significant importance due to a multitude of reasons. One of the key benefits lies in enhancing energy resilience. By incorporating DERs such as PV systems, the EG becomes more robust & reliable [8]. During grid outages or disruptions, DERs can continue supplying power, ensuring a continuous & uninterrupted energy supply. DER integration facilitates grid decentralisation, moving power generation closer to the point of consumption. This decentralisation reduces transmission losses & lessens the need for costly infrastructure upgrades [2]. It enables more efficient distribution of electricity, optimising energy flow within the grid [7].

Additionally, DERs primarily consist of RESs, which enables the seamless integration of clean & sustainable energy into the grid. This, in turn, helps reduce greenhouse gas emissions & combat climate change, contributing to a greener energy landscape [7]. The integration of DERs with energy storage capabilities brings about effective load management & peak tracking. During periods of low energy demand, excess energy can be stored, & during peak hours, it can be released, thereby reducing strain on the grid during high-demand periods & ensuring optimal energy utilisation [2]. This dynamic demand-side management helps in balancing the grid and enhances the overall efficiency of energy distribution [7].

DERs also play a crucial role in supporting grid stability. They can provide supplementary support such as frequency regulation and voltage control, helping to maintain the grid's stability and mitigate potential imbalances. Furthermore, DER integration empowers energy consumers to become prosumers, allowing them to generate their electricity and even sell surplus energy back to the grid [9]. This fosters energy independence and active participation in the energy market, giving consumers more control over their energy consumption and production. Finally, by generating power closer to the demand centres, DERs help alleviate congestion in the transmission lines, leading to cost savings and increased overall grid efficiency, more efficient, and environmentally sustainable energy future [7].

➤ *Challenges of DER Control & Optimisation*

The challenges in optimisation & control of DER encompass several critical areas [10, 11, 9]:

- Grid Integration Challenges: One of the key challenges lies in seamlessly integrating DERs into the existing EG

infrastructure. Issues like voltage regulation, power quality, & grid stability need to be addressed during the integration process.

- **Handling Uncertainties:** DER technologies, such as solar & wind power, are inherently uncertain due to their dependency on weather conditions & external factors. Accurate modelling & accounting for uncertainties in optimisation & control algorithms are crucial for robust decision-making.
- **Scalability & Complexity:** As the deployment of DERs continues to grow, managing & controlling a large number of DER pose scalability challenges. Algorithms should be able to handle the increased complexity of large-scale DER systems & provide efficient solutions.
- **Real-Time Monitoring & Control:** Real-time monitoring & control are critical for the optimal operation of DER systems. Integrating advanced sensor technologies, communication systems, & data analytics with optimisation & control platforms would enable the utilisation of real-time grid measurements, enhance situational awareness, & facilitate adaptive control strategies responding to dynamic grid conditions in real time.
- **Cyber security & Resilience:** With increased reliance on digital communication & control systems, cyber security threats pose significant challenges to the operation & security of DER systems.
- **Integration of Emerging Technologies:** As the energy landscape evolves, new DER technologies & energy storage systems are emerging.
- **Policy & Regulatory Frameworks:** The adoption & successful implementation of optimisation and control techniques for DERs depend on supportive policy and regulatory frameworks.

B. Control & Optimisation Techniques for DERs

Control & optimisation techniques for DERs show a vital role in maximising the efficiency, reliability, & integration of these decentralised power sources into the EG [7]. There are a wide variety of techniques of optimisation technique ranges from straightforward techniques such as Proportional-Integral-Derivative (PID) Control [12] & On/Off Control techniques [13], to more sophisticated techniques such as swarm particle algorithm [14] & neural network technique [15].

Conventional control methods offer straightforward & effective regulation of DERs based on predefined rules & conditions, making them valuable tools across various applications, from individual power generators to interconnected microgrids. PID control, a widely used feedback technique, calculates an error signal by comparing desired setpoints with actual measurements, adjusting gains to achieve stability & steady-state accuracy. On/Off control, toggles DER operation between on & off states based on predefined thresholds, suited for applications where precise control is unnecessary. Meanwhile, droop control is commonly applied in microgrids, where multiple DERs work in parallel, distributing power proportionally to maintain grid stability & balance. Additionally, time-based control schedules DERs to turn on or off at specific intervals or in

response to events, effectively managing energy demand patterns. Lastly, Phase-Locked Loop (PLL) control synchronises grid-connected DERs with the grid's phase angle and frequency, allowing seamless operation and grid stability. Together, these methods provide diverse solutions for regulating DERs with varying complexities & operational requirements.

Complex optimisation techniques for DERs encompass advanced methods designed to address the intricacies and uncertainties present in these decentralised power systems. Among the notable complex optimisation techniques for DERs are Model Predictive Control (MPC) [16] [17], Genetic Algorithms (GA), Simulated Annealing (SA), etc. [18].

Model Predictive Control (MPC) is a dynamic strategy of system controlling that utilises a mathematical model of the DER system to expect the Potential behaviours and enhanced measures for control. By managing an optimising concern while taking restrictions and goals into account at each time step, MPC determines the optimal control inputs that minimise a cost function over a finite time horizon. This approach is particularly effective for real-time DER operation, accommodating complex constraints and managing uncertainties.

The selection of an optimisation algorithm for optimising DER relies on the specific objectives, limitations, and complexity of the DER system under consideration. Researchers have the opportunity to explore different algorithms and compare their performance to determine the most suitable one for a given application. In this study, the researcher adopts the FLC method to enhance the performance of DER in EG. FLC is a robust and versatile technology that offers numerous benefits. It effectively handles uncertainties, captures the nonlinearity inherent in DER systems, ensures transparency and interpretability, enables adaptability and flexibility, and seamlessly integrates with real-time data. FLC empowers DER systems to adapt to changing network conditions, accurately models nonlinear dynamics, instils confidence through transparent decision-making, facilitates troubleshooting, enables dynamic optimisation based on real-time conditions, and enhances overall responsiveness and effectiveness [19]. These advantages underscore the significant value that FLC brings to the control and optimisation of DER within the context of an electrical network.

➤ MATLAB Optimisation Techniques for DERs

Various studies have explored the methodologies & advancements in optimisation & control techniques for the integration & operation of DER. Mathematical models representing different DER technologies have been developed to simulate & evaluate their performance under various operating conditions [8]. To optimise DER operation, researchers have employed optimisation algorithms such as linear programming [20], nonlinear programming [21], & evolutionary algorithms [22], such as Model Predictive Control (MPC) [16, 17], fuzzy logic control (FLC) [23, 11], & Decentralised Control [24]. They are employed to optimise power flow, manage energy storage, & enable effective

demand response in DER. MATLAB's modelling capabilities, along with its efficient solvers & graphical tools, facilitate the simulation & analysis of DER performance metrics. These insights support decision-making processes, allowing researchers to optimise DER operation & assess the impact of different control strategies [11]. MATLAB provides a wide range of optimisation algorithms that can be utilised for optimising the operation of DER within energy systems.

MATLAB also offers mixed-integer programming (MIP) capabilities, which are essential for solving optimisation problems with discrete decision variables [25]. MIP algorithms can be used to optimise the operation of DER systems that involve discrete actions, such as on/off switching of energy storage systems or selecting the optimal configuration of DER resources. Additionally, MATLAB provides the ability to customise & develop new optimisation algorithms using its programming & algorithm development capabilities [11]. This allows researchers to tailor optimisation algorithms specifically for DER operation, considering the unique characteristics & constraints of the energy system.

➤ *Fuzzy Logic Control (FLC) in Distributed Energy Resources (DER)*

FLC is a sophisticated control strategy utilised in DERs management. FLC is well-suited to handle the non-linearities, imprecise data, and uncertainties commonly encountered in DER operations. FLC has linguistic variables & fuzzy sets are used to represent imprecise & uncertain input/output relationships. The control rules are defined using "if-then" statements, allowing FLC to make decisions based on linguistic terms rather than strict binary logic.

By incorporating expert knowledge & historical data, FLC can effectively model the complex relationships between DER inputs & outputs. This approach enables FLC to adapt & optimise control actions based on real-time conditions, improving the efficiency & stability of DER operation. FLC's ability to handle uncertainties besides its simplicity in implementation makes it a valuable control strategy for various DER applications, such as load balancing, & demand response management. As DERs play an increasingly important role in modern energy systems, FLC offers a powerful tool for managing these decentralised resources effectively & optimising their integration into the EG.

➤ *Fuzzy Logic Control (FLC) of DER Using MATLAB*

Using MATLAB's fuzzy logic toolbox, researchers have developed fuzzy inference systems that incorporate linguistic variables, rules, & membership functions to optimise DER operation. Several studies have demonstrated the effectiveness of FLC in optimising the operation of DER in EGs [26]. MATLAB's fuzzy logic toolbox offers various optimisation techniques, such as the Perturbation & observation (P&O) optimisation technique, which can be used to automatically tune the fuzzy inference systems for optimal performance.

Researchers have explored different FLC strategies, including fuzzy-based power dispatch, energy management, & voltage regulation, to enhance the integration & operation of DER. The integration of real-time data acquisition systems with FLC has also been investigated, enabling adaptive & responsive control strategies based on actual grid measurements. The utilisation of FLC in MATLAB for DER offers several benefits [27], are:

- **Robustness to Uncertainties:** Maintaining grid stability is difficult since RESs are inherently variable & energy demand is dynamic. To properly describe & handle uncertainty, FLC integrates linguistic conventions & membership functions. FLC improves resilient performance by altering control actions depending on input variations & conditions, enabling DER systems to adapt to shifting grid conditions & uncertainties [28, 29].
- **Nonlinear System Modelling:** DER systems frequently display nonlinear behaviour, which reduces the efficacy of conventional control methods. With FLC, DER operation is made simpler & complicated interactions between input/output variables are captured, making it possible to handle the nonlinear dynamics of the EG.
- **Transparency & Interpretability:** The FLC control structure is clear & easy to understand. The membership functions & linguistic standards that are employed are generated from expert knowledge & are simple enough for stakeholders and system operators to comprehend and approve. Enhancing trust and acceptance of the control approach is achieved by being able to comprehend and justify control options. FLC's transparency also helps with problem-solving & fine-tuning control settings, guaranteeing efficient and dependable DER functioning.
- **Flexibility & Adaptability:** FLC's flexibility enables it to react in real time to varying system circumstances & uncertainties. Based on the present condition of the DER system & the EG, FLC can modify control actions through its linguistics rules & membership functions. Due to their flexibility, DER components may dynamically adjust their performance in view of variables like the availability of renewable energy, energy demand, and stability. Due to FLC's adaptability, control techniques may be easily modified & expanded as the DER system develops or as new technologies are introduced.
- **Integration with Real-Time Data:** FLC can integrate with real-time data acquisition systems, enabling adaptive control strategies based on actual grid measurements. By continuously monitoring grid conditions, FLC can dynamically adjust control actions to maintain grid stability, optimise power flow, & manage energy storage systems. This integration with real-time data enhances the responsiveness and effectiveness of FLC for DER operation.

III. METHODOLOGY

In renewable energy, using solar panels (photovoltaic or PV arrays) is crucial. This project aims to simulate PV array-grid integration using MATLAB's Simulink, comparing Fuzzy Logic Control (FLC) and Incremental Conductance Control. The goal is to enhance renewable energy management by analysing their performance. Figure 1

presents the diagram of the paper proposed, depicting the stages and elements engaged in this study:

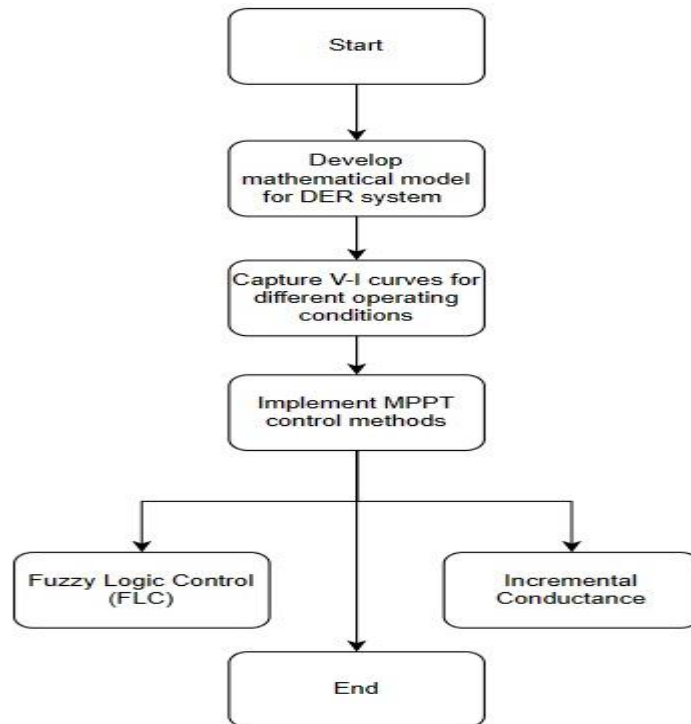

Fig. 1: Methodology steps

A. Problem Formulation:

The problem of this research involves designing a control system to maximise energy production for a DER that includes a linked PV system to the utility grid. The goal is to operate the PV system at its maximum power point (MPP) under various environmental conditions & system parameters. This is achieved through an AFLC that dynamically adjusts control parameters based on real-time feedback & changing environmental conditions, ensuring

effective integration with the grid and maximising the use of clean energy from renewable sources.

B. Distributed Energy Resources Modelling:

In this step, the mathematical model for the DER system will be developed. This model captures the power output characteristics, such as the V-I curves, for different operating conditions.

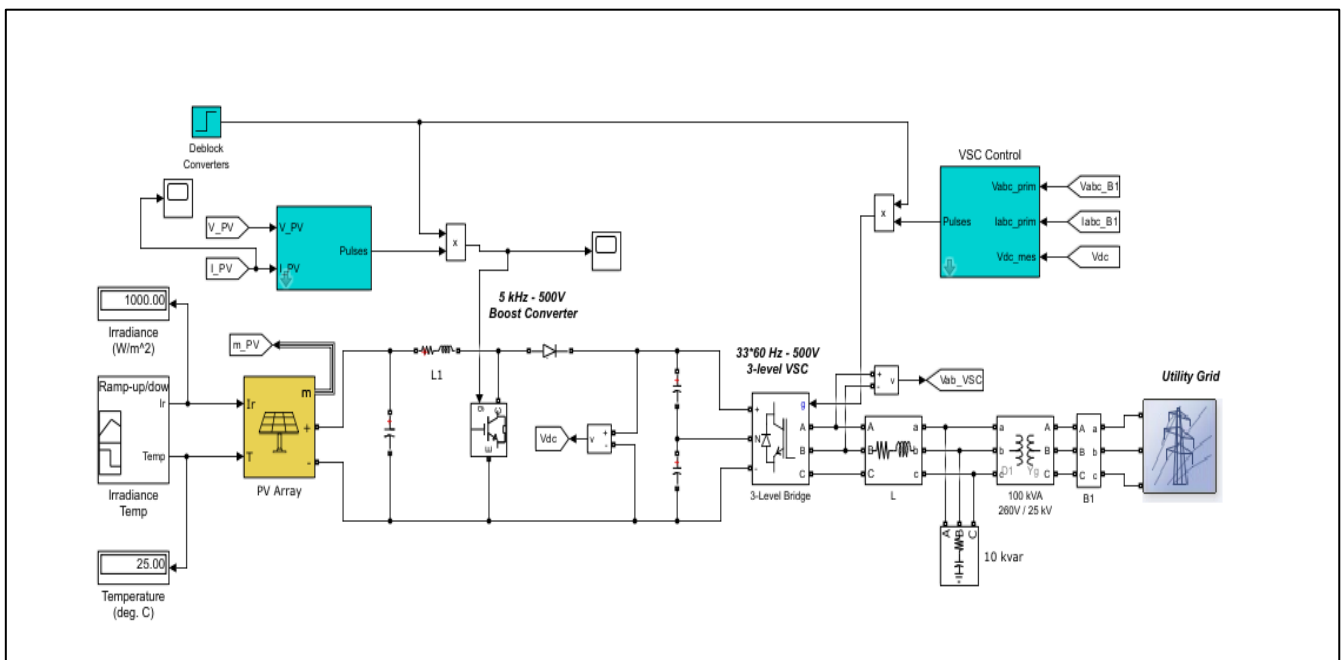

Fig. 2: Grid-Connected PV Array with MPPT controller

➤ *Characteristics of photovoltaic cells*

The supposed DER system in this research is a PV system with a three-phase inverter and boost converter. In this

system, the equivalent circuit of PV cell represented in Figure 2 below:

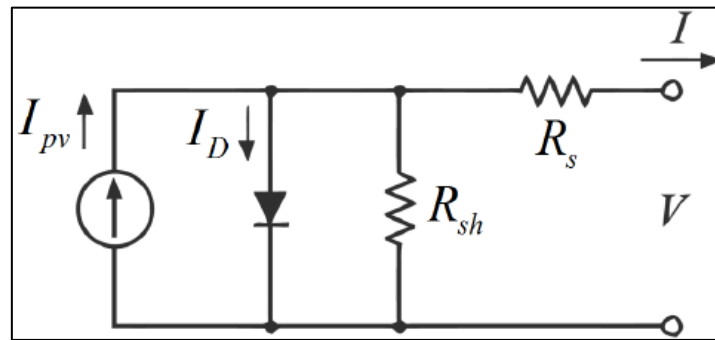

Fig. 3: Photovoltaic cell equivalent circuit.

The PV cell current equation is gotten from Kirchhoff's law as:

$$I_o = I_{pv} - I_D - I_{sh}$$

$$I_D = I_o \left\{ \exp \left(\frac{q(V + I_o R_s)}{A k T} \right) - 1 \right\}$$

$$I_{sh} = \frac{V + I_o * R_s}{R_{sh}}$$

Then, the final equation is:

$$I_o = I_{pv} - I_o \left\{ \exp \left(\frac{q(V + I_o R_s)}{A k T} \right) - 1 \right\} - \frac{V + I_o * R_s}{R_{sh}}$$

Where I_o and V represent output current and voltage, respectively, I_{pv} represents the photo generated current, I_D represents the diode current, q represents the electronic charge, A represents diode characteristic factor, k represents the Boltzmann constant, T represents the actual temperature, and R_{sh} and R_s are the parallel and string resistor, respectively. Meanwhile R_s value is small and R_{sh} value is large.

Changes in the environment can influence the PV cell efficiency, a phenomenon obvious through alterations in the cell's P-V and I-V curves. As illustrated in following figures curves show the PV cell behaviour during changing irradiance and temperature:

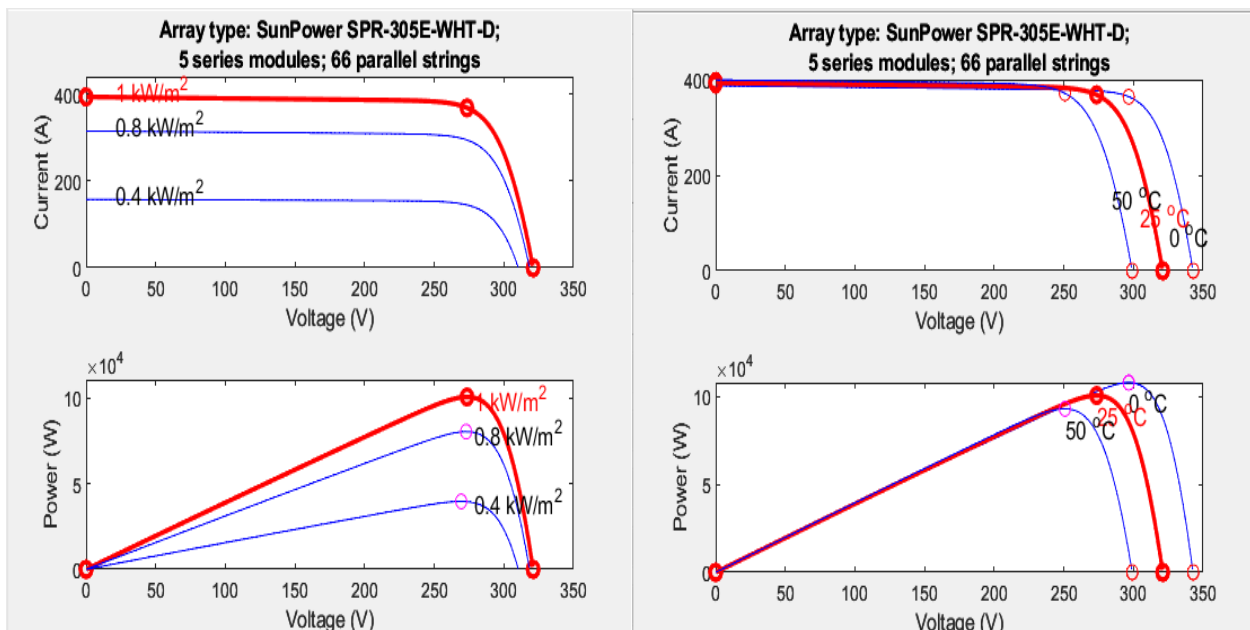

Fig. 4: IV curve under environment variations

Meteorological elements significantly dictate the PV cell power generation. When irradiance keeps constant, the P-V curve displays a solitary MPP. Furthermore, when the temperature keeps constant while irradiance differ and vice-versa, the MPP also differs. It seems that the MPP rises alongside augmented irradiance, representing a positive

correlation. However, as irradiance amplifies, the voltage at the MPP experiences minimum fluctuation, while the current shows more notable differences in comparison to the value of voltage. The figure (3) below illustrates the block parameters of the used PV system:

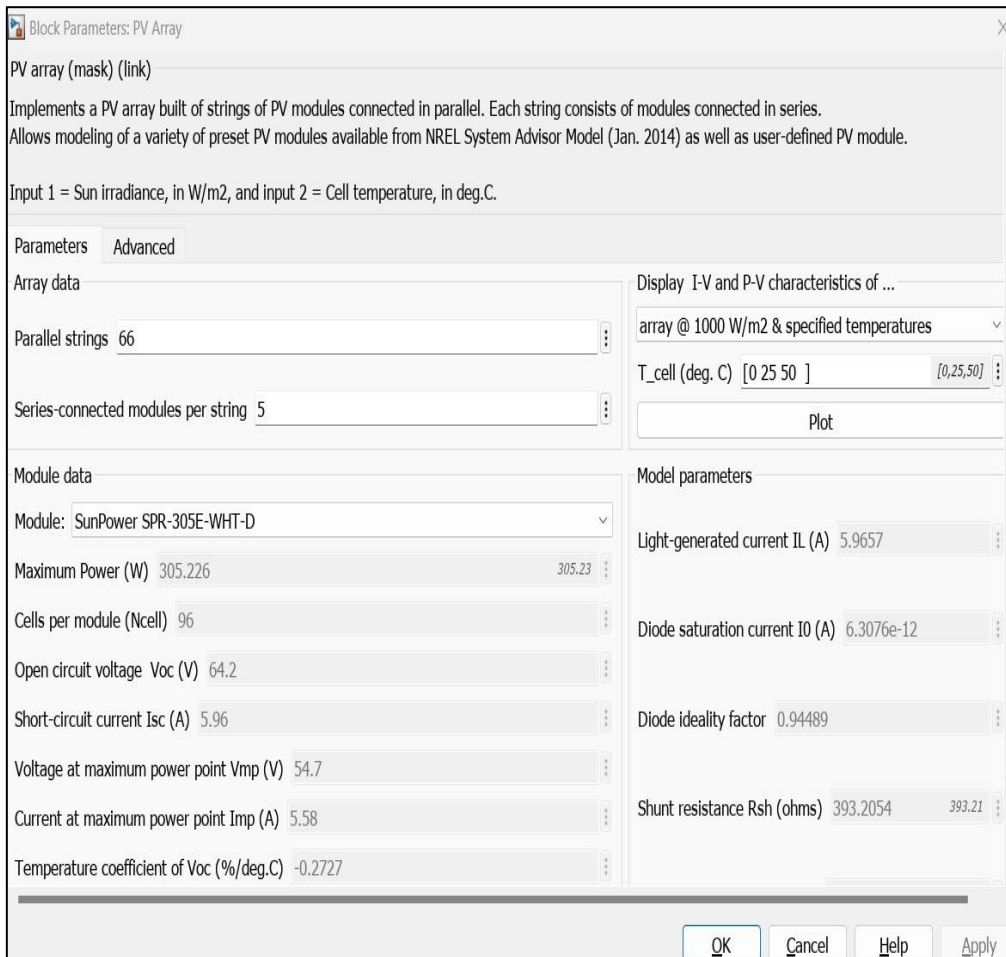

Fig. 5: PV array parameters

➤ *MPPT Control Method*

The Maximum Power Point (MPP) is achieved. Keeping stability at the MPP need the MPPT algorithm to modify output based on several condition of environmental. The MPPT controller calculates, adjusts, and monitors power output, directing the working point to the MPP. By measuring variations in voltage, and current after and before tracking, the following tracking direction is determined. While the direction remains the same, power output rises consistently, and tracking continues similarly in the following cycle. Tracking shifts direction until the PV panel output reaches the MPP. However, there are several algorithms and methods for the control of MPPT. These methods goal to extract the

maximum available power from solar panels by animatedly adjusting their operating points based on varying factors for instance temperature and solar irradiance.

➤ *Incremental Conductance*

The Incremental Conductance Technique, also known as the Incremental Conductance Algorithm, is a technique utilised for maximum power point tracking (MPPT) in photovoltaic (PV) schemes. MPPT is important in PV array to enhance the energy output by continuously adjusting the PV panels operating point to the point where the maximum power is produced. Figure 1 represents the c by using MATLAB Simulink:

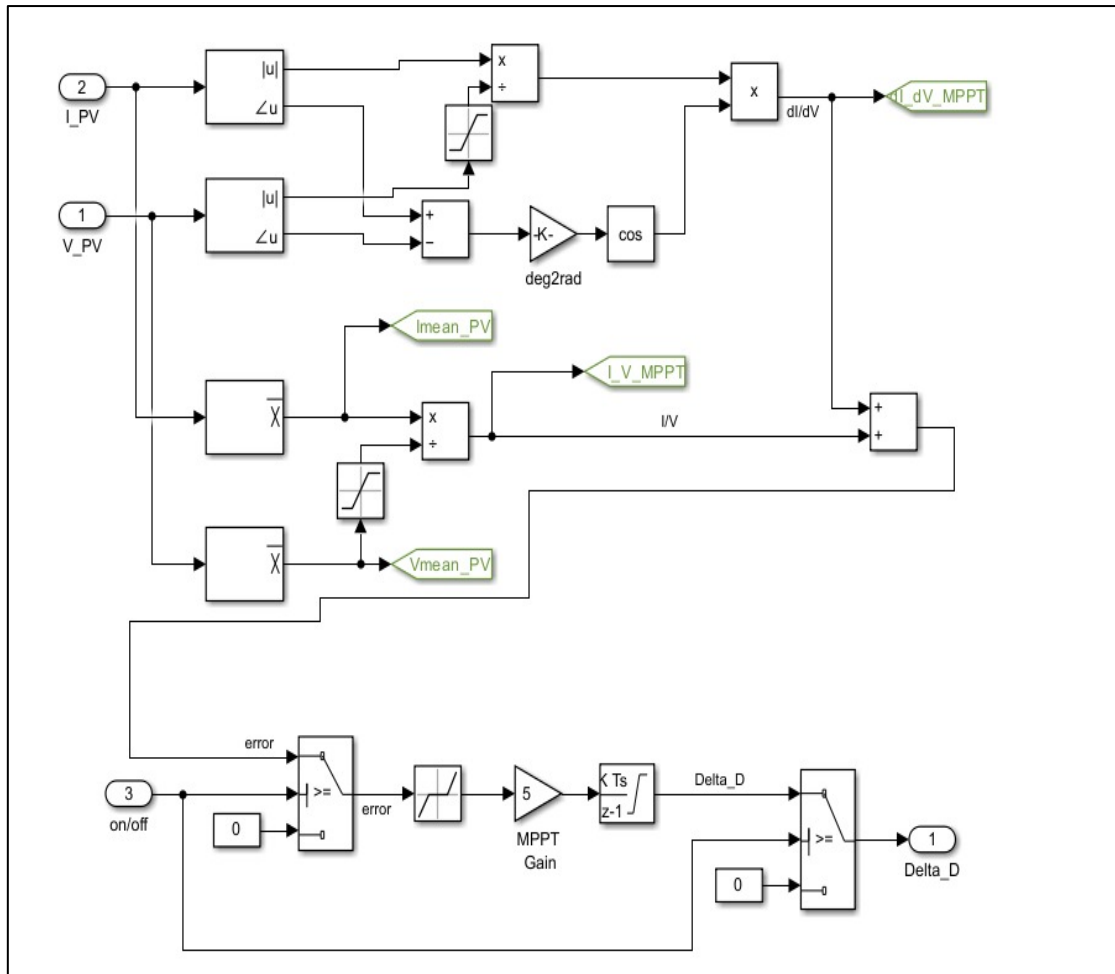

Fig. 6: Incremental Conductance Method blocks

Also, it is one of the several algorithms utilised for MPPT. It works by evaluation the voltage-current (V-I) curve of the PV system to determine the point of maximum power. The aim principle behind this method is that the slope of the power curve is zero at the MPP. Consequently, the algorithm searches for the point where the incremental variation in power with respect to incremental variations in voltage is zero.

The following is explanation of how the Incremental Conductance Technique works:

- Measure the PV module's current (I) and voltage (V).
- Incrementally variation the voltage slightly and measure the new current.

- Calculate the incremental variation in voltage (ΔV).
- Calculate the conductance (dI/dV) at the new point of voltage and compare it with the conductance at the previous point.
- If the conductance changes sign from positive to negative, the previous voltage was closer to the MPP. Adjust the voltage in the opposite direction. If the conductance keeps positive, continue changing the voltage.

The following figure shows the flow chart of Incremental Conductance method:

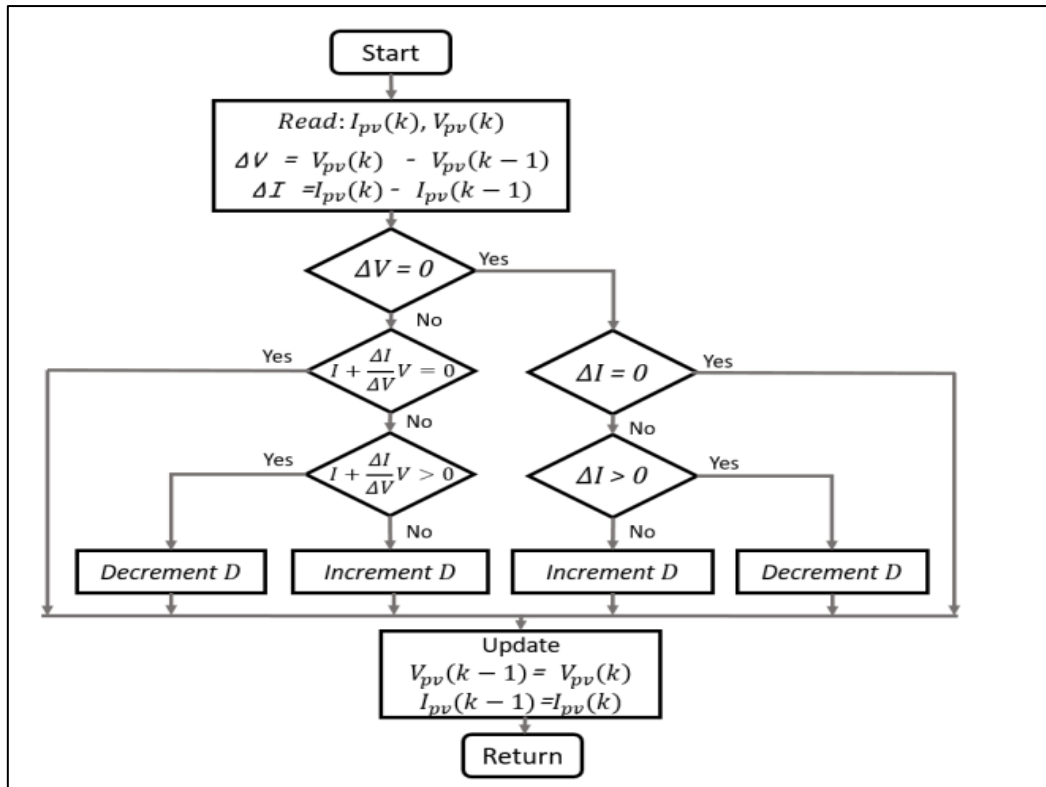

Fig. 7: Incremental conductance chart

The Incremental Conductance Method is capable of tracking MPP during rapidly changing conditions for instance varying temperature and irradiance. Nevertheless, it may oscillate around MPP in some situations, leading to inefficiencies.

➤ *Boost converter*

A boost converter is employed to manage MPPT and raise the magnitude of PV array voltage. For the purpose of driving controllable switches, a pulse is produced using the MPPT controller which in return it uses Incremental Conductance pulse width modulation (PWM) methods.

➤ *Three-Phase inverter*

Which is an electronic device utilising a semi-conductor switch and PWM, converting a DC power to an AC power. The inverter plays a vital role for applications such as renewable control, motor and industrial process. The grid's voltage and the converted voltage must be synchronising to inject this converted voltage into the grid. This injection is managed smartly by grid tied PV systems, taking into consideration some important variables such as irradiance and grid conditions, all the while conforming to regulations and possibly presenting incentives for system proprietors.

C. Utility-Grid

Grid utility refers to the complex system of generating, **transmitting**, and distributing electricity to users. It includes power plants, **feeders**, substations, and sharing networks. Grid managers keep a balance between supply and demand, making sure everything works well and can handle challenges. This system is getting smarter with technology, making energy use efficient and adding renewable sources. It's super important for a steady power supply, needing careful planning and growth as energy needs change. The **system used** has a big 2500 MVA generator at 120 KV, changed to 25 KV later **by a step down transformer**. A 30 MW power user and 2 MVAR reactive power keep things steady. **Feeders** send power **effectively** between users and transformers.

D. Fuzzy Logic Controller

Fuzzy logic controllers (FLC) find wide utility in the realm of renewable energy applications. The adoption of fuzzy logic controllers has observed substantial growth in the past ten years, primarily due to their straightforward nature, adeptness at managing vague inputs, independence from precise mathematical models, and capacity to address nonlinear characteristics. A notable application involves utilizing fuzzy logic controllers as regulators to extract the utmost power achievable from photovoltaic (PV) modules amid fluctuating weather conditions. Figure (8) shows the PV system controlled by FLC and figure (9) demonstrates the components of the FLC system.

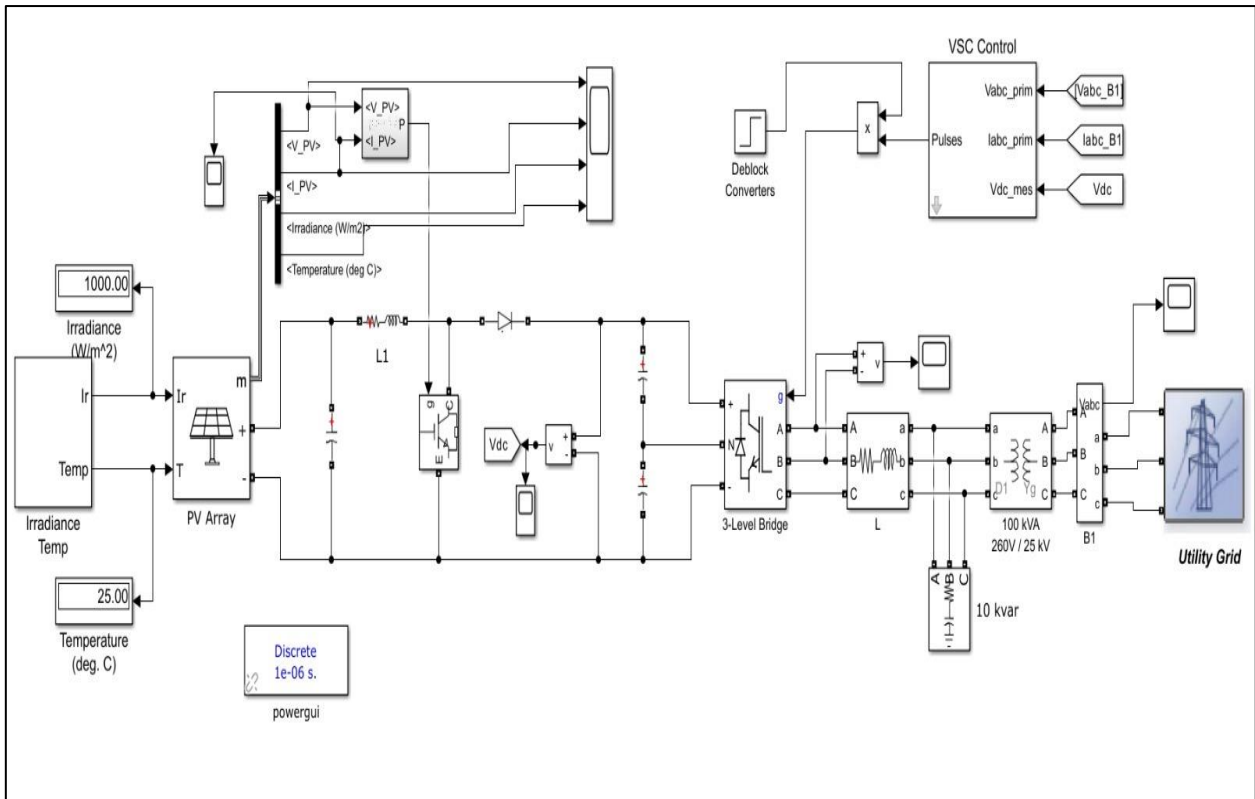

Fig. 8: Grid-Connected PV Array with fuzzy logic controller

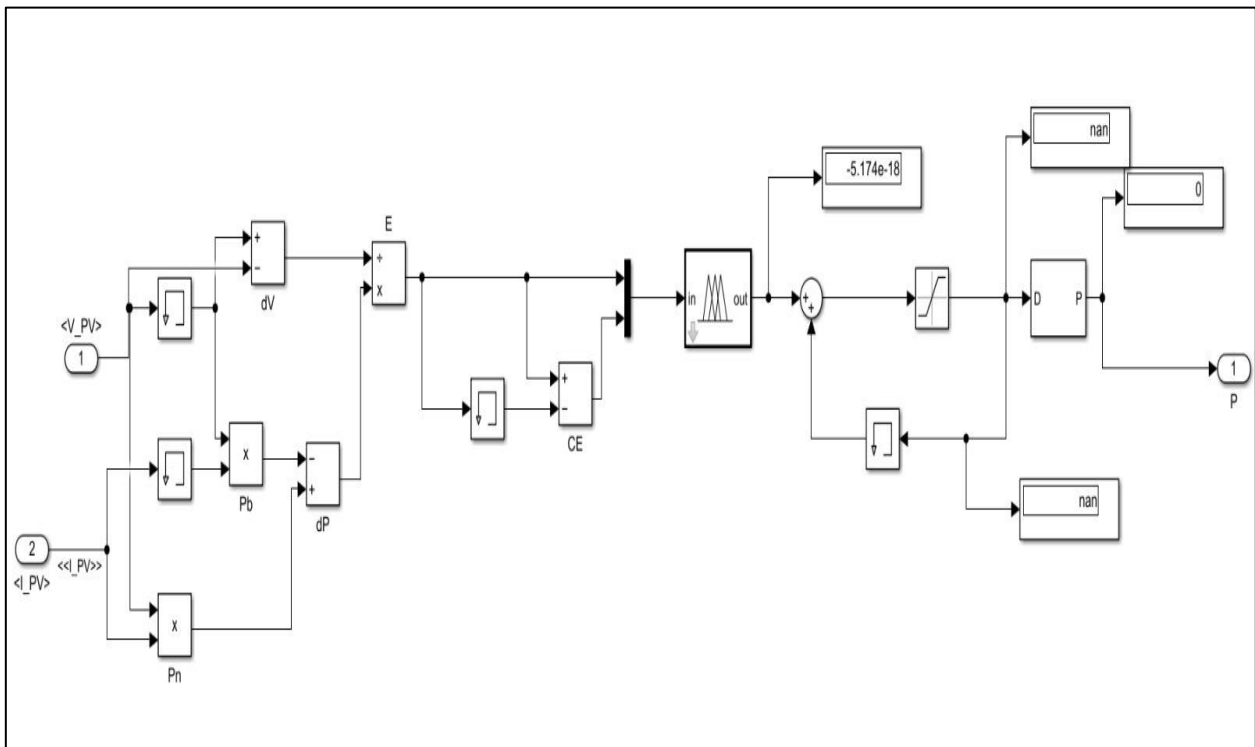

Fig. 9: Fuzzy logic controller block

The FLC will substitute the proportional-integral controller. FLC doesn't demand a precise model due to the simplicity for being generated. It works exceptionally well in managing the intricate dynamics of DFIG (Doubly Fed Induction Generator) systems, ensuring reliability and

simplicity. Despite having no definite, non-linear, or changing models FLC can still handle variations in parameters, performing consistently. Designing an FLC includes a main stages are shown below in figure (10):

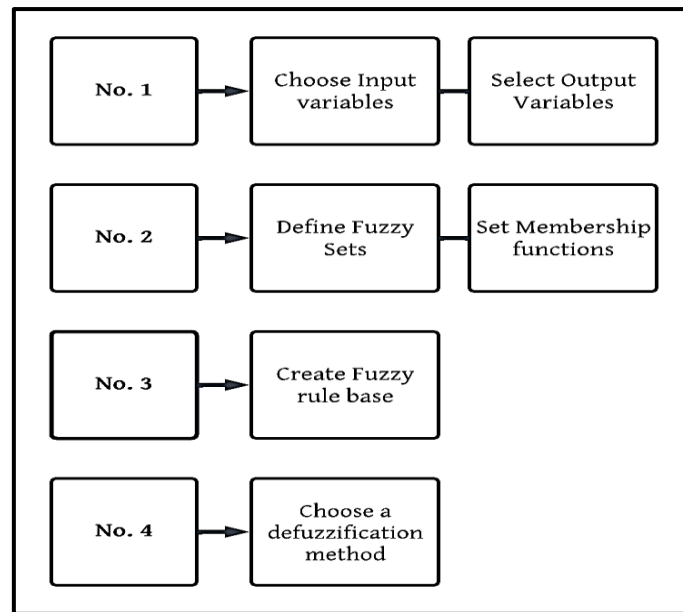

Fig. 10: Fuzzy logic design steps

Within the intentional control approach, the FLC utilises inputs such as rotor current error (e(t)) and its rate of change (de(t)). The output will be the rotor current's parameters. The FLC constantly adapts these parameters using the error method and its derivative. This guarantees that the rotor's current aligns with the desired reference.

The Fuzzy Logic Toolbox offers resources and capabilities to design, simulate, and implement a fuzzy logic systems. The toolbox allows to generate, edit, and assess fuzzy inference systems using either a visual interface or MATLAB scripts. The diagram (Figure 11) below provides a visual depiction of the FLC system's design and the connections between inputs and outputs.

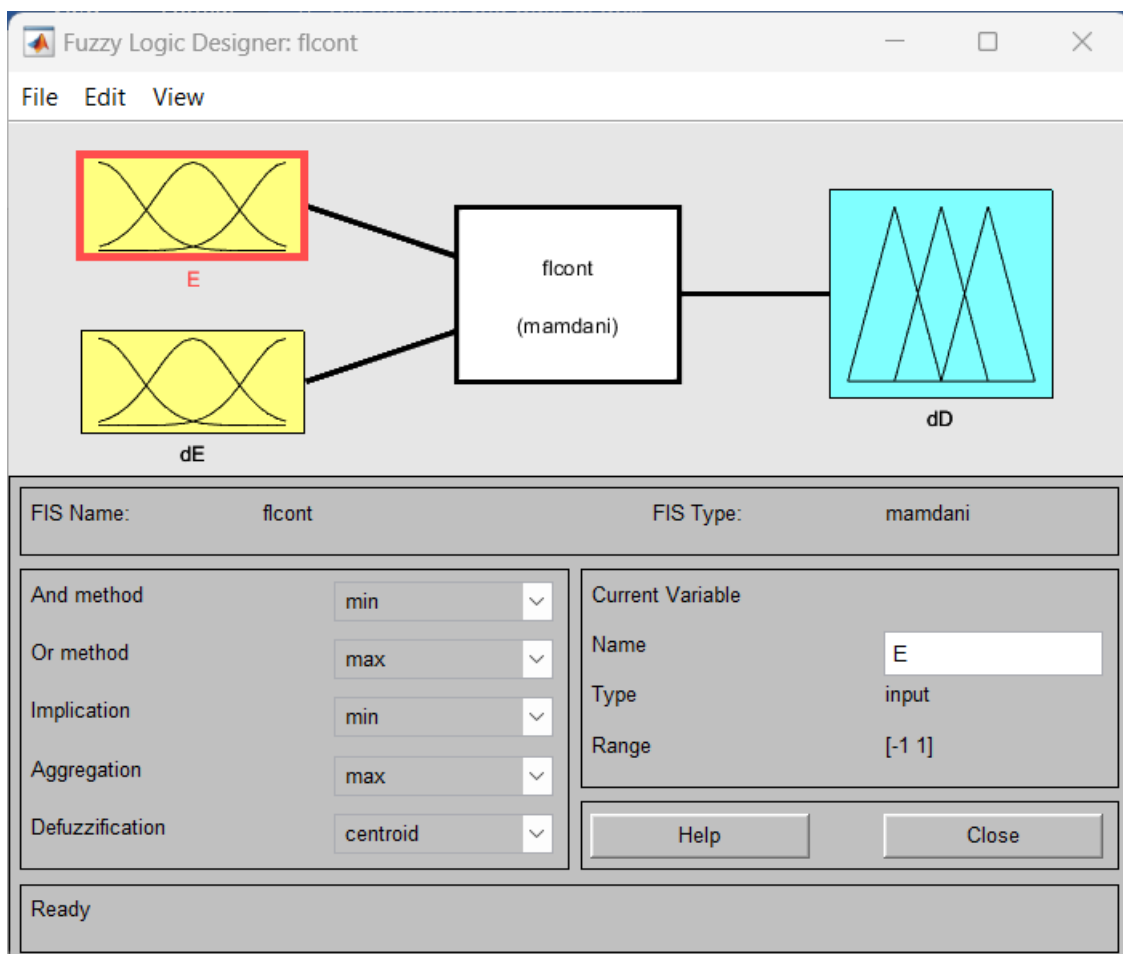

Fig. 11: FLC designer

Membership functions constitute a core component of FLC, establishing the link between input values and linguistic terms such as "low," "medium," and "high." These functions assign a membership degree between 0 and 1, signifying an input's association with a specific term. Membership functions possess varied shapes, like triangular or Gaussian, guided by parameters that dictate their behavior. They hold a pivotal role in fuzzy rule assessment, aggregation, and defuzzification, empowering fuzzy logic controllers to navigate uncertainty and make choices using imperfect data.

In this design, the FLC's membership functions are devised to achieve desired response outcomes. Membership functions for input variables in fuzzy logic systems ascertain how inputs correspond with linguistic terms. These functions, influenced by parameters, measure membership strength between inputs and terms. They are pivotal for fuzzification, rule assessment, and aggregation, amplifying the system's capacity to manage imprecise data and decisions rooted in ambiguous inputs. Membership functions bridge real-world data and fuzzy sets, augmenting the system's adaptability in intricate and uncertain scenarios. Figure (12) illustrates the design of FLC membership input functions.

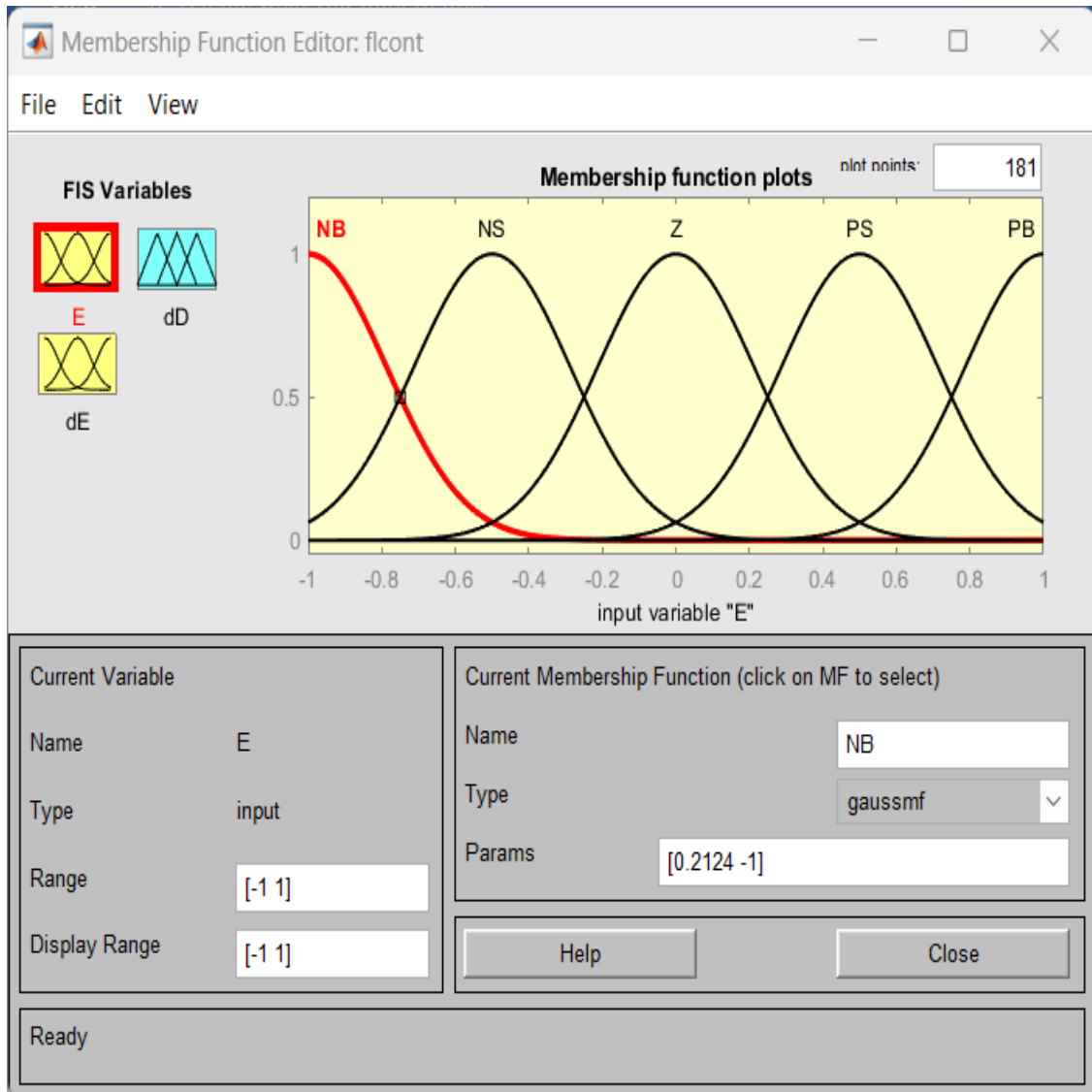

Fig. 12: Membership functions of Inputs

In fuzzy logic systems, membership functions for output variables establish how aggregated fuzzy outputs spread across linguistic terms such as "cool," "moderate," and "hot." These functions, shaped by their form and parameters, assign degrees of membership to each term based on the combined fuzzy outputs. When defuzzification occurs, these

degrees affect the computation of a final crisp output value that steers control actions. Output membership functions are vital for transforming combined fuzzy data into practical control choices. The design will involve 5-membership functions for both the output and input, incorporating trapezoidal and triangular functions illustrated in figure (13).

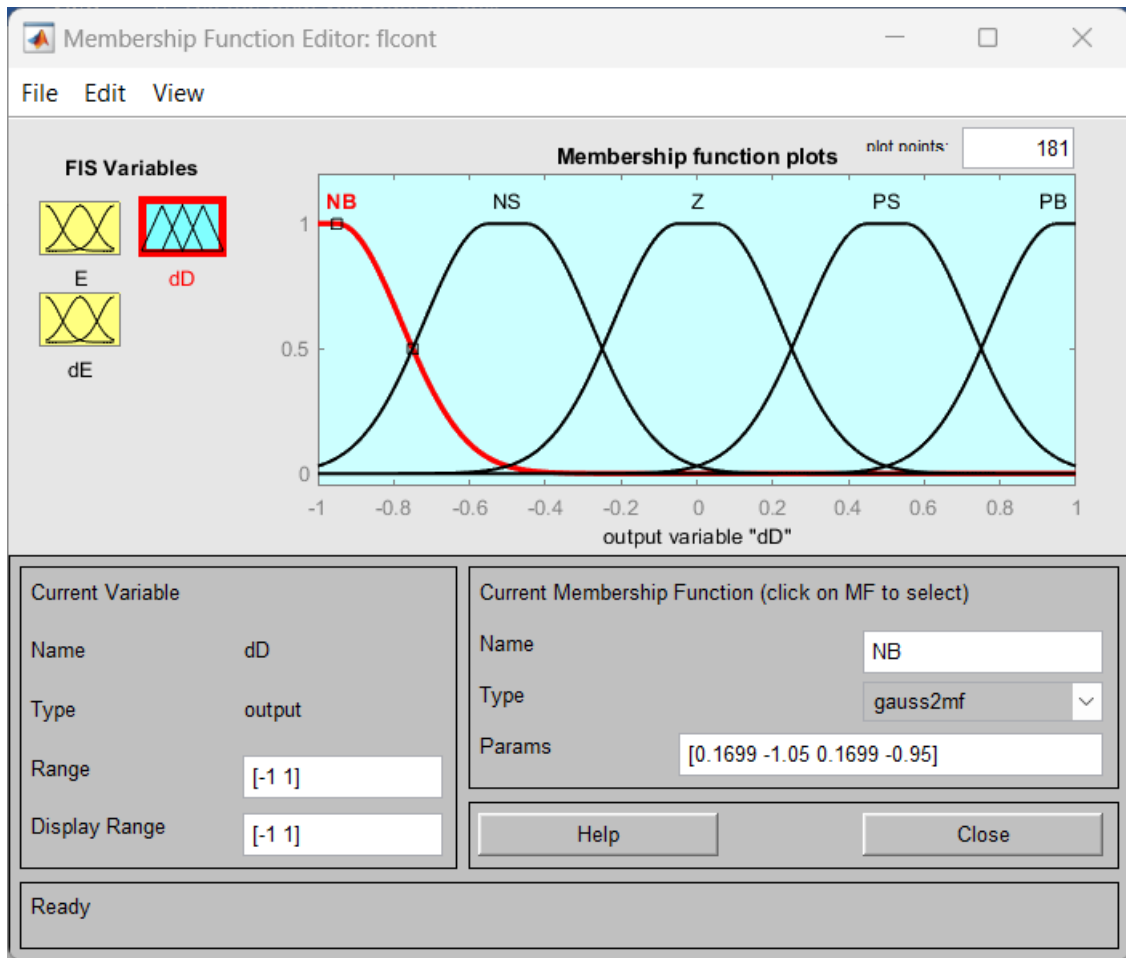

Fig. 13: Membership functions of Output.

IV. SIMULATION RESULTS & DISCUSSION

The results of an extensive investigation into the application of Fuzzy Logic Control (FLC) for addressing enhanced voltage oscillation are detailed and deliberated in this section. Diverse scenarios are meticulously examined in the research, each illuminating the response of the system to the employed control methodology. Through a thorough analysis of the system's behaviour under different conditions, a more comprehensive understanding of the capabilities and

limitations of this utilized soft computing technology can be garnered. The outcomes elucidated in this chapter offer valuable insights into the efficacy of FLC in enabling consistent energy management, a factor of significant consequence for the advancement of Renewable Energy Sources (RESs) and the stability of micro-grids.

A. System inputs with various environmental conditions

Figure (14) shows the variation of the environmental conditions to study its effectiveness on the system.

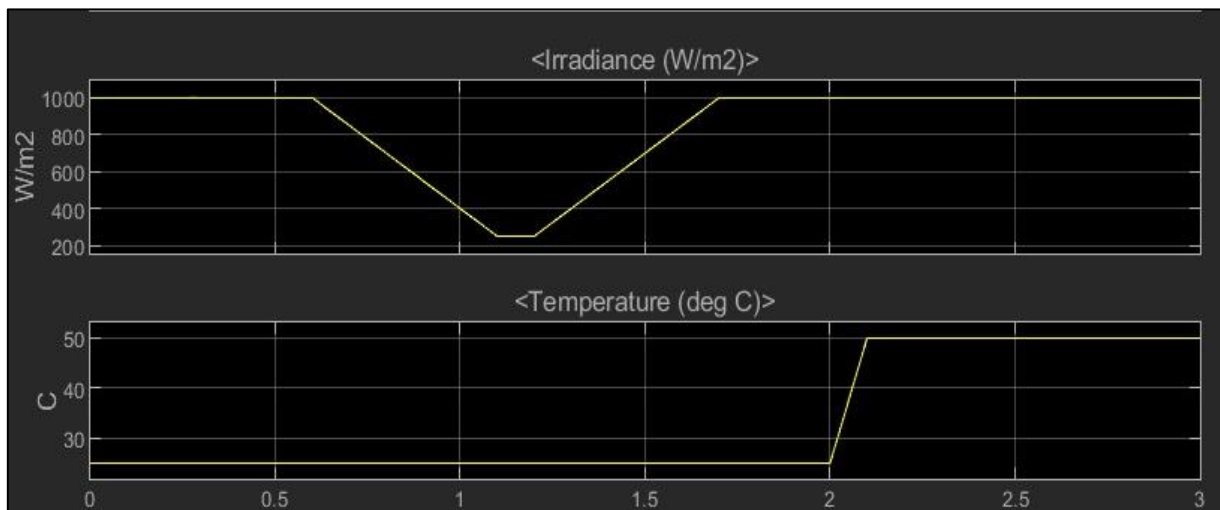

Fig. 14: PV array Parameters

B. Case 1: Using MPPT controller with Incremental Conductance

The results of this case with using MPPT controller with a variable irradiation and temperature are crucial in understanding how the system reacts to the changes of environmental conditions as shown in figure (14).

To analyse this complex behaviour, the boosted voltage and the bridge output voltage have been monitored under this control method. Figure (14) shows the output voltage of the boost converter using MPPT method control, in which the oscillation demonstrated in the waveform due to the existence of harmonics and losses.

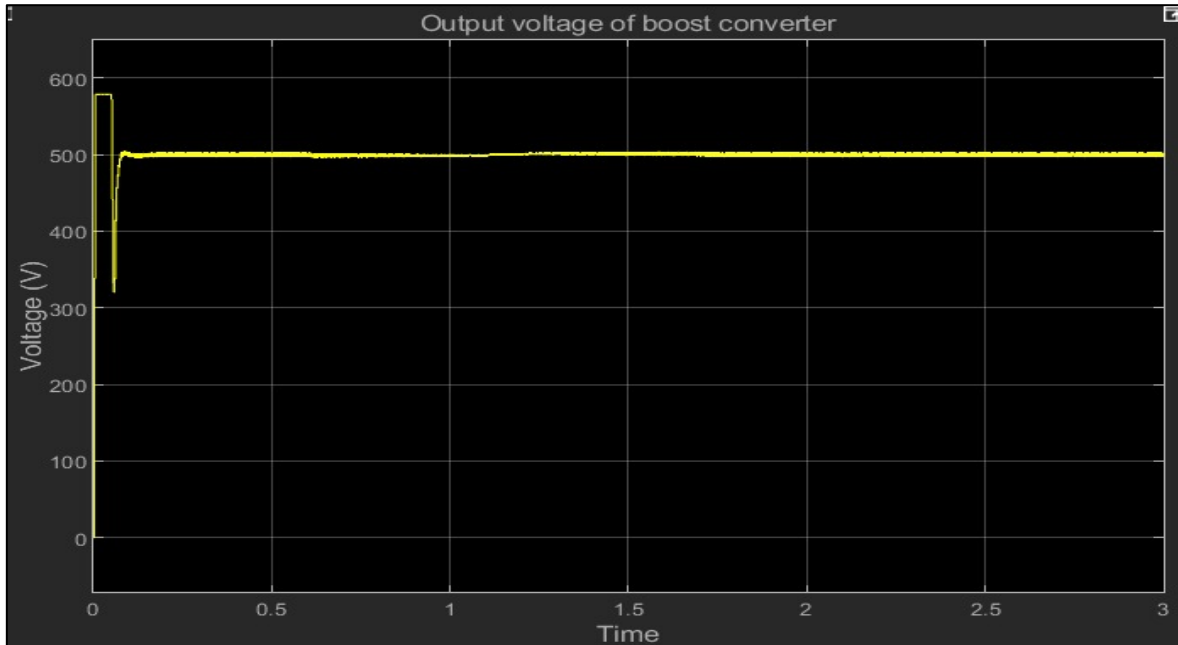

Fig. 15: Output voltage of boost converter

As noted in the figure above, in this case, the behaviour of the boost converter voltage is tested under the respective of MPPT control method and variable environmental conditions of solar radiation and temperature. The oscillation

demonstrated in the waveform due to the existence of harmonics and losses will affect the output voltage of the three-level bridge inverter, which is revealed in Figure (16).

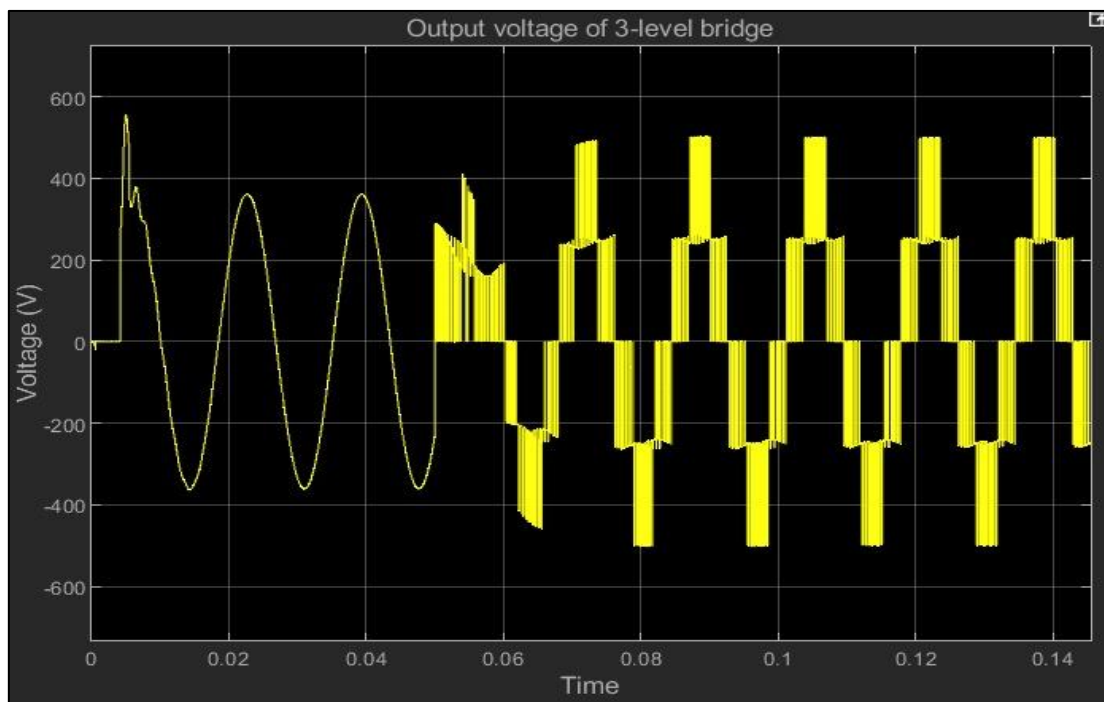

Fig. 16: three-level bridge voltage

As shown in the above figure, the three-level bridge output voltage that will be injected into the grid is affected by the applied control method.

C. Case 2: Using FLC method

This case illustrates the effect of applying the FLC method instead of the MPPT method the oscillation has been eliminated so the output voltage of the boost converter will be more stable, under the same various conditions of the environment as shown in figure (17).

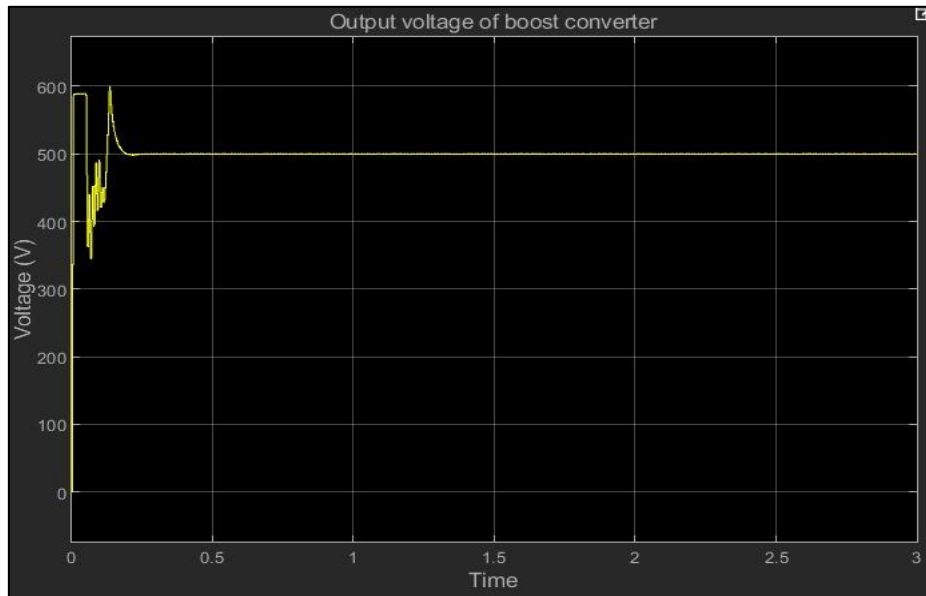

Fig. 17: Output voltage of boost converter controlled by FLC

As noted in the above figure, and due to the elimination of the oscillation; the output voltage of the three-level bridge inverter will be slightly affected due to this optimisation.

Figure (18) demonstrates the output voltage of the three-level bridge inverter.

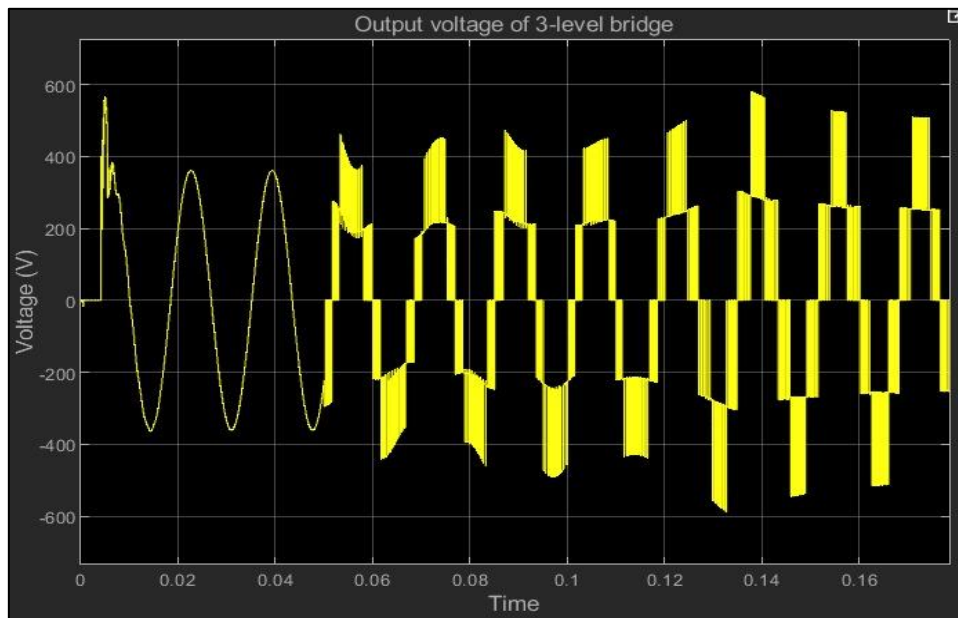

Fig. 18: three-level bridge voltage

D. Both Cases Comparison

In this section, evaluation of the system's performance in two cases: one using a Fuzzy Logic Controller (FLC) and the other using a conventional Maximum Power Point Tracking (MPPT) controller based on Incremental Conductance methods is presented. this analysis focuses on how the FLC

controller works better than the MPPT controller in terms of minimizing oscillations in the boost converter's output voltage, decreasing settling time, and boosting stability. To demonstrate the benefits of the FLC technique, the evaluation is undertaken under a variety of circumstances. Figure 19 illustrates output voltage of boost converter in both cases:

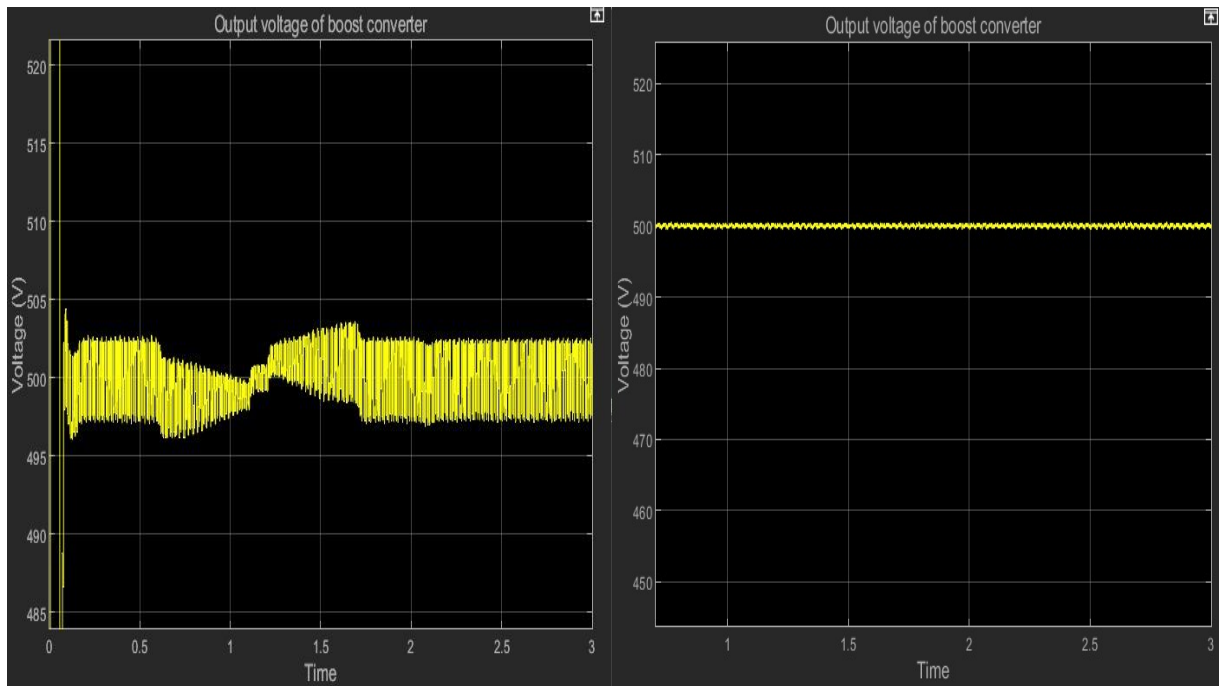

Fig. 19: A comparison of output voltage of boost converter in both cases

The decrease in output voltage oscillations in the boost converter, illustrated in Figure 19, is one of the key signs of efficient control. When compared to the MPPT controller, the FLC controller dramatically reduces voltage fluctuations, demonstrating greater performance. Instability is caused by output voltage oscillations, which may negatively impact downstream components. Smoother and more accurate voltage regulation is made possible by the FLC's capacity to modulate control inputs based on fuzzy principles.

A key element in achieving rapid and accurate control is the system's settling time, which is the amount of time it takes for the output voltage to arrive at and remain within a specific range of the intended setpoint. When compared to the MPPT controller, the FLC controller displays faster settling times. The FLC's ability to adapt in real time enables it to respond to changes in load or solar irradiation more quickly.

When designing a control system, stability is a crucial factor, especially for dispersed energy supplies. By rapidly reacting to disturbances and making ensure that the output voltage stays near to the reference value, the FLC controller excels at preserving system stability. The system's overall resilience is improved by its fuzzy rule-based approach, which enables efficient management of nonlinearities and uncertainties.

The assessment of system performance was conducted under a range of scenarios, including varying solar irradiance levels, sudden load changes, and transient disturbances. In each case, the FLC controller consistently demonstrated superior performance over the MPPT controller. The FLC's adaptability and rule-based decision-making allowed it to smoothly handle diverse operating conditions, leading to improved overall system behaviour.

V. CONCLUSION

In conclusion, this endeavour has proven to be a successful exploration of the efficacy of FLC when applied to a photo-voltaic (PV) system seamlessly integrated with the utility grid. The integration is achieved through a meticulously designed DC-DC boost-converter system, coupled with a sophisticated three-level bridge inverter. The primary objective of this integration is to ensure the steadfast maintenance of a stable boost voltage that emanates from the PV system.

Throughout the course of this project, a comprehensive analysis and evaluation of the FLC's performance in this specific context have been conducted. The implementation of FLC has showcased its capability to effectively manage the voltage oscillations that often accompany photovoltaic systems, especially when interfacing with the utility grid. By harnessing the adaptability and intelligence of fuzzy logic, the control system has demonstrated its capacity to swiftly and accurately respond to dynamic changes in voltage conditions. This dynamic response mechanism plays a pivotal role in mitigating boosted voltage oscillations and subsequently safeguarding the stability of the entire system.

One of the notable achievements of this project is the successful orchestration of the DC-DC boost-converter system in tandem with the three-level bridge inverter. This harmonious collaboration is instrumental in maintaining the desired boost voltage levels and facilitating a smooth energy flow between the PV system and the utility grid. The FLC acts as a vital control element, making real-time decisions based on fuzzy rules that encompass a broad spectrum of operational scenarios. This adaptability ensures that the system remains agile and responsive, optimizing energy transfer efficiency while averting voltage fluctuations that could otherwise disrupt grid synchronization.

REFERENCES

- [1.] M. Hafner, S. Tagliapietra, L. de Strasser, M. Hafner, S. Tagliapietra and L. de Strasser, "Prospects for renewable energy in Africa," *Energy in Africa: challenges and opportunities*, pp. 47-75, 2018.
- [2.] O. Edenhofer, L. Hirth, B. Knopf, M. Pahle, S. Schlömer, E. Schmid and F. Ueckerdt, "On the economics of renewable energy sources," *Energy Economics*, vol. 40, pp. 12-23, 2013.
- [3.] Rahman, O. Farrok and M. Haque, "Environmental impact of renewable energy source based electrical power plants: Solar, wind, hydroelectric, biomass, geothermal, tidal, ocean, and osmotic," *Renewable and Sustainable Energy Reviews*, vol. 161, p. 112279, 2022.
- [4.] Y. Hou, R. Vidu and P. Stroeve, "Solar energy storage methods," *Industrial & engineering chemistry research*, vol. 50, no. 15, pp. 8954-8964, 2011.
- [5.] L. Schwartz, M. Wei, W. Morrow, J. Deason, S. Schiller, G. Leventis, S. Smith, Leow, W.L., T. Levin, S. Plotkin and Y. Zhou, "Electricity end uses, energy efficiency, and distributed energy resources baseline," 2017.
- [6.] K. Kumar and B. Jaipal, "The role of energy storage with renewable electricity generation," *Electric Grid Modernization*, 2022.
- [7.] M. Akorede, H. Hizam and E. Pouresmaeil, "Distributed energy resources and benefits to the environment," *Renewable and sustainable energy reviews*, vol. 14, no. 2, pp. 724-734, 2010.
- [8.] S. Al-Imran, F. M. T. Ahmed, M. Ali and M. Maruf, "Optimization of distributed energy resources to balance power supply and demand in a smart grid," *IEEE*, pp. 1-5, 2015.
- [9.] S. Muhanji, A. Muzhikyan and A. Farid, "Distributed control for distributed energy resources: Long-term challenges and lessons learned," *IEEE Access*, vol. 6, pp. 32737-32753, 2018.
- [10.] H. Sun, Q. Guo, J. Qi, V. Ajarapu, R. Bravo, J. Chow, Z. Li, R. Moghe, E. Nasr-Azadani, U. Tamrakar and G. Taranto, "Review of challenges and research opportunities for voltage control in smart grids," *IEEE*, vol. 34, no. 4, pp. 2790-2801, 2019.
- [11.] V. Nikam and V. Kalkhambkar, "A review on control strategies for microgrids with distributed energy resources, energy storage systems, and electric vehicles," *International Transactions on Electrical Energy Systems*, vol. 31, no. 1, p. 12607, 2021.
- [12.] R. Alayi, F. Zishan, S. Seyednouri, R. Kumar, M. Ahmadi and M. Sharifpur, "Optimal load frequency control of island microgrids via a PID controller in the presence of wind turbine and PV," *Sustainability*, vol. 13, no. 19, p. 10728, 2021.
- [13.] N. Murgovski, L. Johannesson and J. Sjöberg, "Engine on/off control for dimensioning hybrid electric powertrains via convex optimization," *IEEE Transactions on Vehicular Technology*, vol. 62, no. 7, pp. 2949-2962, 2013.
- [14.] L. Wong, S. Rahim, M. Sulaiman and O. Aliman, "Distributed generation installation using particle swarm optimization," *IEEE*, pp. 159-163, 2010.
- [15.] M. Hassan, N. Bailek, K. Bouchouicha and S. Nwokolo, "Ultra-short-term exogenous forecasting of photovoltaic power production using genetically optimized non-linear auto-regressive recurrent neural networks," *Renewable Energy*, vol. 171, pp. 191-209, 2021.
- [16.] M. Rahmani-Andebili and H. Shen, "Cooperative distributed energy scheduling for smart homes applying stochastic model predictive control," *IEEE*, pp. 1-6, 2017.
- [17.] J. Ma, F. Yang, Z. Li and S. Qin, "A renewable energy integration application in a microgrid based on model predictive control," *IEEE*, pp. 1-6, 2012.
- [18.] D. Gómez-Lorente, I. Triguero, C. Gil and A. Estrella, "Evolutionary algorithms for the design of grid-connected PV-systems," *Expert Systems with Applications*, vol. 39, no. 9, pp. 8086-8094, 2012.
- [19.] D. Faouzi, N. Bibi-Triki, B. Draoui and A. Abène, "Modeling a fuzzy logic controller to simulate and optimize the greenhouse microclimate management using MATLAB SIMULINK," *International Journal of Mathematical Sciences and Computing*, vol. 3, no. 3, pp. 12-27, 2017.
- [20.] Q. Shi, F. Li, M. Olama, J. Dong, Y. Xue, M. Starke, C. Winstead and T. Kuruganti, "Network reconfiguration and distributed energy resource scheduling for improved distribution system resilience," *International Journal of Electrical Power & Energy Systems*, vol. 124, p. 106355, 2021.
- [21.] M. Silva, H. Morais and Z. Vale, "An integrated approach for distributed energy resource short-term scheduling in smart grids considering realistic power system simulation," *Energy Conversion and Management*, vol. 64, pp. 273-288, 2012.
- [22.] Essiet, Y. Sun and Z. Wang, "Analysis of the effect of parameter variation on a dynamic cost function for distributed energy resources: A DER-CAM case study," *Applied Sciences*, vol. 8, no. 6, p. 884, 2018.
- [23.] H. Hasaniien and M. Matar, "A fuzzy logic controller for autonomous operation of a voltage source converter-based distributed generation system," *IEEE*, vol. 6, no. 1, pp. 158-165, 2014.
- [24.] G. Fusco and M. Russo, "A decentralized approach for voltage control by multiple distributed energy resources," *IEEE*, vol. 12, no. 4, pp. 3115-3127, 2021.
- [25.] E. Bacca, A. Knight and M. Trifkovic, "Optimal land use and distributed generation technology selection via geographic-based multicriteria decision analysis and mixed-integer programming," *Sustainable Cities and Society*, vol. 55, p. 102055, 2020.
- [26.] Talwariya, P. Singh, M. Kolhe and J. Jobanputra, "Fuzzy logic controller and game theory based distributed energy resources allocation," 2020.
- [27.] L. Suganthi, S. Iniyan and A. Samuel, "Applications of fuzzy logic in renewable energy systems—a review," *Renewable and sustainable energy reviews*, vol. 48, pp. 585-607, 2015.
- [28.] H. Hasaniien and M. Matar, "A fuzzy logic controller for autonomous operation of a voltage source converter-based distributed generation system," *IEEE*, vol. 6, no. 1, pp. 158-165, 2014.

- [29.] W. Dong, Q. Yang, X. Fang and W. Ruan, "Adaptive optimal fuzzy logic based energy management in multi-energy microgrid considering operational uncertainties," *Applied Soft Computing*, vol. 98, p. 106882, 2021.
- [30.] N. Patcharaprakiti, S. Premrudeepreechacharn and Y. Sriuthaisiriwong, "Maximum power point tracking using adaptive fuzzy logic control for grid-connected photovoltaic system," *Renewable energy*, vol. 30, no. 11, pp. 1771-1788, 2005.
- [31.] M. AlHajri, M. AlRashidi and M. El-Hawary, "Improved sequential quadratic programming approach for optimal distribution generation deployments via stability and sensitivity analyses," *Electric Power Components and Systems*, vol. 38, no. 14, pp. 1595-1614, 2010.
- [32.] V. Mihaly, M. Stănese, M. Şuşcă and P. Dobra, "Interior Point Methods for Renewable Energy Management," *IEEE*, pp. 1-6, 2020.
- [33.] M. Sedighzadeh and A. Rezazadeh, "Using genetic algorithm for distributed generation allocation to reduce losses and improve voltage profile," *World Academy of Science, Engineering and Technology*, vol. 37, no. 1, pp. 251-256, 2008.
- [34.] B. Ahmadi, O. Ceylan and A. Ozdemir, "A multi-objective optimization evaluation framework for integration of distributed energy resources," *Journal of Energy Storage*, vol. 41, p. 103305, 2021.