

# Monitoring and Automated Chemical Spraying System for Food Transportation Using IoT system Smart IoT for Food Safety

Vanithadevi K.<sup>1</sup>; Dhanya Shree J.<sup>2</sup>; Jeevitha R.<sup>3</sup>; Deepika R.<sup>4</sup>; Sofia M.<sup>5</sup>

<sup>1,2,3,4,5</sup>Department of Biotechnology, Salem College of Engineering and Technology Salem-Attur Main Road, Nh-68Mettupatty-Perumapalayam Salem Tamil Nadu India 636111

Publication Date: 2026/04/24

**Abstract:** This project introduces an advanced AI- integrated IoT framework for real-time food quality monitoring and intelligent preservation during storage and transportation. The system combines multiple sensing, vision, and control components to automate decision-making based on environmental and spoilage indicators. The primary sensors DHT22 (temperature & humidity), pH sensor (surface acidity for spoilage), and MQ-135 gas sensor (CO<sub>2</sub>, ammonia) interface with an ESP32 microcontroller for edge-level data acquisition. Sensor data is cross-validated with a curated dataset of fruit and perishable conditions. Based on pre-trained AI models, the system classifies food items as Fresh, Warning, or Spoiled. Simultaneously, a Raspberry Pi module processes visual data from an onboard camera, capturing periodic images of food. These images are pre-processed (e.g., colour correction, noise reduction) and analyzed via CNN-based image classification to detect discoloration, Mold, or deformities. A pneumatic spray system is triggered conditionally to apply food-safe preservatives, such as Sodium Benzoate, and a UV-C light sterilization module is activated when microbial contamination risk is high. The system also pushes data to the ThingSpeak cloud for visualization, alert generation, and remote decision control. Real-time alerts are sent via email/SMS to the supply chain manager. The combined use of sensor fusion, machine learning, edge computing, and vision-based diagnostics reduces spoilage, enhances transparency, and ensures high-quality food delivery in cold chain logistics and smart agriculture.

**Keywords:** Food Spoilage Detection, Pneumatic Sprayer, Raspberry Pi, ESP32, IoT, Gas Sensor.

**How to Cite:** Vanithadevi K.; Dhanya Shree J.; Jeevitha R.; Deepika R.; Sofia M. (2026) Monitoring and Automated Chemical Spraying System for Food Transportation Using IoT System Smart IoT for Food Safety. *International Journal of Innovative Science and Research Technology*, 11(4), 1714-1721. <https://doi.org/10.38124/ijisrt/26apr895>

## I. INTRODUCTION

Developed an excellent surveillance framework that maximizes food security and traceability by use of composite sensor-based technology. Their processors can identify risk of contamination in real time due to their features of multi-sensors and centralized processing of data. This work proves that sensor fusion plays an important aspect in food safety monitoring. We also propose to run a system that combines cloud reporting and several sensors in real-time quality assurance. Proposed an Internet of Things-based routing system that can enhance the functionality of the food supply chain towards sustainable smart cities. Their model would employ data analytics and the solution to the smart path selection that would enable a higher food freshness and delivery effectiveness. Even though the focus is put on optimizing logistics, it also improves our approach toward monitoring the state of food in real time during transport.

Described an architecture of managing food safety based on the idea of IoT and focusing on cloud-based

notifications and modular networks of the sensors. The primary goals of their strategy are system scalability, remote monitoring, and complying with regulation. Our model extends this framework by adding automated methods to preservation with AI-powered classification. Developed a smarter tracking and monitoring solution when it comes to automated food and e-commerce robotic delivery. Their hack is an amalgamation of package monitoring, obstacle detection and location tracking. Regardless of the fact that they specialize in robotics, their expertise on automated distribution can be used. Described an architecture of managing food safety based on the idea of IoT and focusing on cloud-based notifications and modular networks of the sensors. The primary goals of their strategy are system scalability, remote monitoring, and complying with regulation. Our model extends this framework by adding automated methods to preservation with AI-powered classification. Developed a smarter tracking and monitoring solution when it comes to automated food and e-commerce robotic delivery. Their hack is an amalgamation of package monitoring, obstacle detection and location tracking.

Regardless of the fact that they specialize in robotics, their expertise on automated distribution can be used to supplement our aim of autonomous quality control systems within mobile environments. Developed a holistic IoT-based framework to recharge traceability gaps in the fresh produce supply chains. They have shown in a study how end-to-end visibility is possible as the sensor feedback is in real-time when it comes to a farm to retailer end. The quality monitoring and spoil alerts at every stage of transportation adopted by Our Work aids to achieve their traceability goals.

Here we are going to discuss different sections are: In section II: will look into the related research works, section III: will discuss on Materials and Methods which is proposed in this paper, section IV: Results and discussion, section V: Conclusion and at the end of our discussion, in section VI: will see reference papers[1].

## II. RELATED WORK

To detect spoiling conditions Krishnan et al. (2024) proposed an AI-based Internet of Things that utilizes machine learning in conjunction with sensor output to monitor the quality of food in real-time. To achieve real-time notification and predictive analytics, their technology leverages the capability that wireless connection brings into the picture. In the research, the effectiveness of smart automation in food logistics is demonstrated. This corresponds well to the real-time cloud-based monitor set-up which we have proposed.

Kim et al. (2020) note the example of the IoT applications in agricultural automation with the use of sensors to control the data analytics, control a particular environment, and ensure efficiency of operations. In their study, they show how precision farming and decision-making can be made possible due to IoT. We have our built on this sensor-based automation paradigm. The use of pneumatic sprayers in our project is inspired by the fact that they are specialized in the control systems.

In order to enhance food safety in processing facilities, Kolikopogu et al. (2025) implemented an Internet of Things-based climate monitoring system. The study places a strong emphasis on employing sensor-based automation to maintain ideal conditions, such as temperature and humidity. Their emphasis on places that are safe for food is really pertinent to our approach that is centred on transportation. We apply this idea to logistics for mobile cold chains. A semi-autonomous IoT-based agricultural sprayer vehicle was created by Padhiaryet al. (2025). It uses environmental data and GPS to automate the application of pesticides. Their sprayer control logic helps the development of our preservation spraying system, despite its agricultural focus. Their research confirms that pneumatic spraying is a practical method.

Vedantam et al. (2024) provided a comprehensive picture of how the IoT may be applied to agriculture and food. They identified critical benefits such as traceability, monitoring in real time, and reduced wastes. Their observations speak in Favor of the fact that cloud-based IoT solutions like Thing Speak are used more and more. Our

technology builds upon these advances in the case of applications in food transit. Mishra et al. offered a proposal of an IoT-enabled food drying system that monitors the levels of moisture and adjusts the drying conditions accordingly in 2023. They conduct studies on the area of sensor-based adaptive control. It complements our design philosophy, which employs computerized preservation with stimulus through environmental feed-back. Their system is also modular with the approach we have[2,3,4].

The Drifty is a cost-effective IoT environment created by Aira et al. (2024) that monitors the spraying of pesticides. Their experiment shows that dynamic outdoor environments of sensing and spraying cost-effectively can be done precisely. This goes in line with our Nematic sprayer that we use to spray the preservatives accurately on the way. As is our threshold-based sprayer, their approach to drift reduction ensures food security. In, Sobhan et al. (2025) presented real-time biosensors to monitor the risks in food packaging enabled by IoT. Similar to how we use MQ-135, their biosensor network helps in detecting signs of rotting such as emission of gases. In their study, the focus of the research is on low-power, compact solutions; these are the main principles of our implementation based on ESP32.

Bhutta and Ahmad (2021) had spoken about safe monitoring of a food supply chain using IoT with real-time traceability and tracking. Their system makes data available and intact in the course of transportation. The same objective is adopted in our project where live data is uploaded to the cloud and alerts are enabled. Their focus on the traceability shapes our implications in the usage of cloud platforms. Amer et al. (2025) created and experimented with the prototype of an IoT food traceability as a part of smart logistics. The paper is about digital monitoring and notification based on the condition with embedded devices. In their findings, they indicate better accountability and turnaround time. This justifies the real time alert and analysis feature that we incorporate using Thing Speak[5,6].

## III. MATERIALS & METHODS

To develop an entire interface of the automatic chemical spraying of foods in transit and live monitoring of food quality, a combination of deep sensor-based technology, artificial intelligence (AI), Internet of Things (IoT) will be used in this project. Among the essential schemes of hardware, there is Raspberry Pi 4 and ESP32 microcontroller, which serve as the primary data processing and obtaining nodes. Temperature reading is provided by the DHT22 sensor, acidity of the surface is measured by pH sensor, gases that detect the spoilage (such as ammonia or carbon dioxide as examples) can be detected via the MQ-135 gas sensor. Visual assessment is done using a high-resolution camera that is connected to the Raspberry Pi and takes periodic pictures. These photos are pre-processed in such a way as colour normalization, noise removal, and other procedures before applying to implement its classification model based on a convolutional neural network to identify spoilage evidence such as Mold, discoloration, or deformation. The AI model will be able to define the current food status in

Fresh, Warning, or Spoiled by matching sensor data to a curated dataset that will include the thresholds of each food product spoiling. A pneumatic sprayer functions automatically by spraying a preservative (sodium benzoate) which is safe to food in case a warning or spoiled condition occurs. A UV-C light sterilizing module was also made on to reduce possible microbiological contamination. The

collected data is put on the cloud platform called Thing Speak to enable analysis of the remote data. Through the SMS or email the logistic managers are alerted with signs. The sensor-fusion and AI-based feature makes this ideal in cold chain logistics and smart agriculture as there is less manual handling involved and the quality of food is ensured shown in [7,8]figure 1.

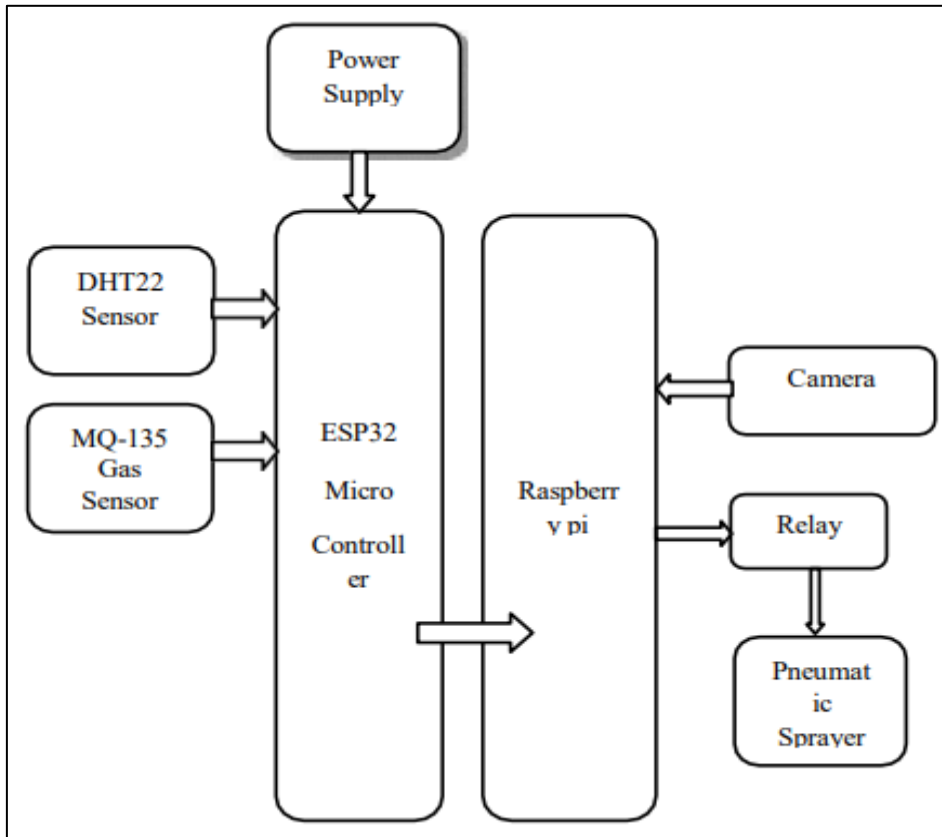

Fig 1 Proposed Work Block Diagram

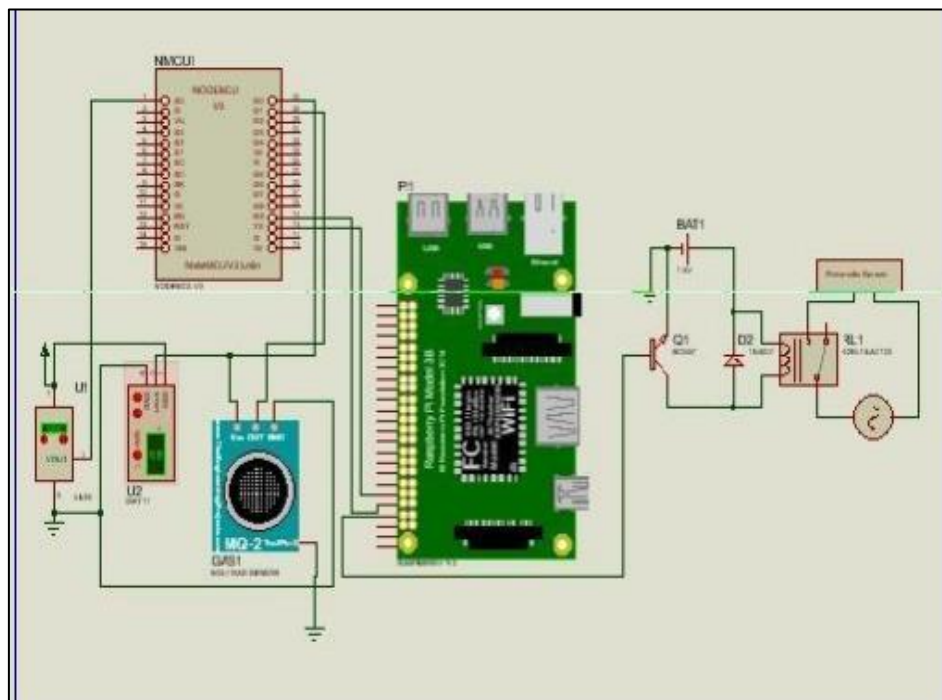

Fig 2 Circuit Diagram

This figure 2 represents an IoT-based gas leakage detection and alert system. It includes an MQ-2 gas sensor for detecting gas presence, connected to a NodeMCU microcontroller that processes the sensor data. The NodeMCU is interfaced with a Raspberry Pi board, enabling Wi-Fi-based communication for remote monitoring. A relay module is used to control an external device (such as an alarm or exhaust fan) in response to gas detection. The circuit also includes a power supply unit and LED indicators to show system status. When gas is detected, the system activates the relay and sends alerts via IoT connectivity.

➤ *ESP32 Controller*

A line of low-cost, low-power system-on-a-chip microcontrollers featuring dual-mode Bluetooth and integrated Wi-Fi is called ESP32. The ESP32 series incorporates built-in antenna switches, RF balun, power amplifier, low-noise receive amplifier, filters, and power-management modules. It uses either an Xtensa LX6 microprocessor in both dual-core and single-core variations, an Xtensa LX7 dual-core microprocessor, or a single-core RISC-V microprocessor. Shanghai-based Espressif Systems is the creator and developer of ESP32, which is produced by TSMC utilizing their 40 nm technology. The pin diagram of the ESP32 controller shown in figure 3.

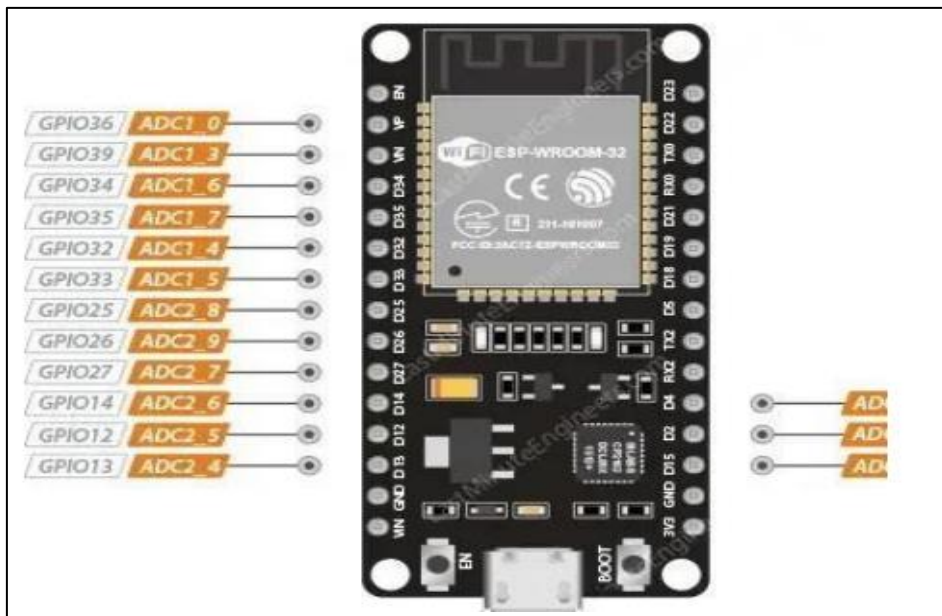

Fig 3 Analog Pin Diagram of ESP32 Controller Raspberry Pi

The Raspberry Pi refers to a small cheap, one-board PC used in the IoT and embedded systems. It is utilized as the central aspect of image processing of this project and vision-based food quality examination. It accesses pictures using a connected camera and uses preprocessing effects on it such as colour correction and noise removal. The processed photos

are then classified via CNN model in order to detect the presence of spoiling, i.e. by the presence of Mold or discolouration. It is ideal to be used in real-time AI implementation in food monitoring systems as shown in figure 4 since it can run the Linux-based operating system and supports Python.



Fig 4 Raspberry Pi

➤ *DHT22 Sensor*

The figure 5 DHT22 sensor is a digital device which is capable of measuring the temperature and the humidity very accurately and hence is an ideal gadget to be used in Internet of Things networks with regard to monitoring the environment via the sensors. It sends/receives a use-single-wire-digital- signal and operable within a wide temperature

range of -40 o C to +80 o C and 0-100 % humidity. With this project, the storage conditions of the food items are being constantly monitored during transportation. The red circle in figure 4 shows the benefits of real- time data that it provides, which helps in detecting unfavourable conditions which may accelerate spoilage.



Fig 5 DHT22 Sensor

➤ *MQ-135 Gas Sensor*

The MQ-135 gas sensor can find hazardous gasses like carbon dioxide, ammonia and other volatile organic compounds (VOCs) in the air. They are commonly used in air quality monitoring and environmental sensing due to their sensitivity and also rather wide range of sensing. This study

has necessitated the use of the MQ-135 to identify gasses that are emitted when transporting food by rotting or rotten foods. To maintain quality of food and activate automatic preservation processes, this information helps make decisions in real-time shown in figure 6.



Fig 6 MQ-135 Gas Sensor

➤ *PH Sensor*

The pH sensor is used to check the acidity level or alkalinity level of a substance using values ranged between 0-

14 and the value of 7 indicating neutral ground. The pH sensor of this project monitors the acidity level of the surfaces of perishable food stuffs which is known to fluctuate as the

food decays. A dip or increase in pH above the normal is an indication of microbial activity or breakdown. Based on this real time pH data, the system, shown in figure 7, then detects

initiation of the spoiling and applies appropriate corrective actions to counteract spoiling in food during the transportation process.



Fig 7 PH Sensor

➤ *Camera*

The module is mostly installed on top of a Raspberry Pi to capture images of the food as it is transported and maintained. These photos have to be pre-processed to remove noise and adjust colour before being analyzed by Convolutional Neural Network (CNN) to detect visual signs of spoiling: Mold, discolouration, or deformation. To have a

more accurate assessment of the quality of food, this kind of vision-based monitoring along with the sensor data is integrated. In case spoilage is detected, the system is able to institute proper action as shown in figure 8, which may include spraying with preservatives or sending notification, etc.



Fig 8 Camera

➤ *Relay*

As figure 9 indicates Relays An electrically driven switch that uses low-power control signals to operate high-power devices, e.g. the signals generated by the Raspberry Pi or the ESP32 microcontrollers. The relay module in this project has been used based on the detection of spoilages in

order to turn on or off things such as the UV-C sterilizing light and pneumatic sprayer. When the system determines there is low quality of food the relay is sent a signal to release the preservation devices. This ensures that food delivery system is operated automatically, safely and effectively with respect to its hardware.



Fig 9 Relay Module

➤ *Pneumatic Sprayer*

Pneumatic sprayers will atomize and spray liquids (such as sodium benzoate and other preservatives that are safe to use in food) onto perishable goods using compressed air. The technology of this project is preset to work automatically only in situation of detecting spoiling through sensors or image

analysis. The sprayer enhances the food shelf life due to its action of preventing the multiplication of the microbes that cause the food to go bad and also maintains on the food freshness during transportation. Its proper, automated usage will reduce the personal intervention requirement, will be less wasteful, and will guarantee safety.

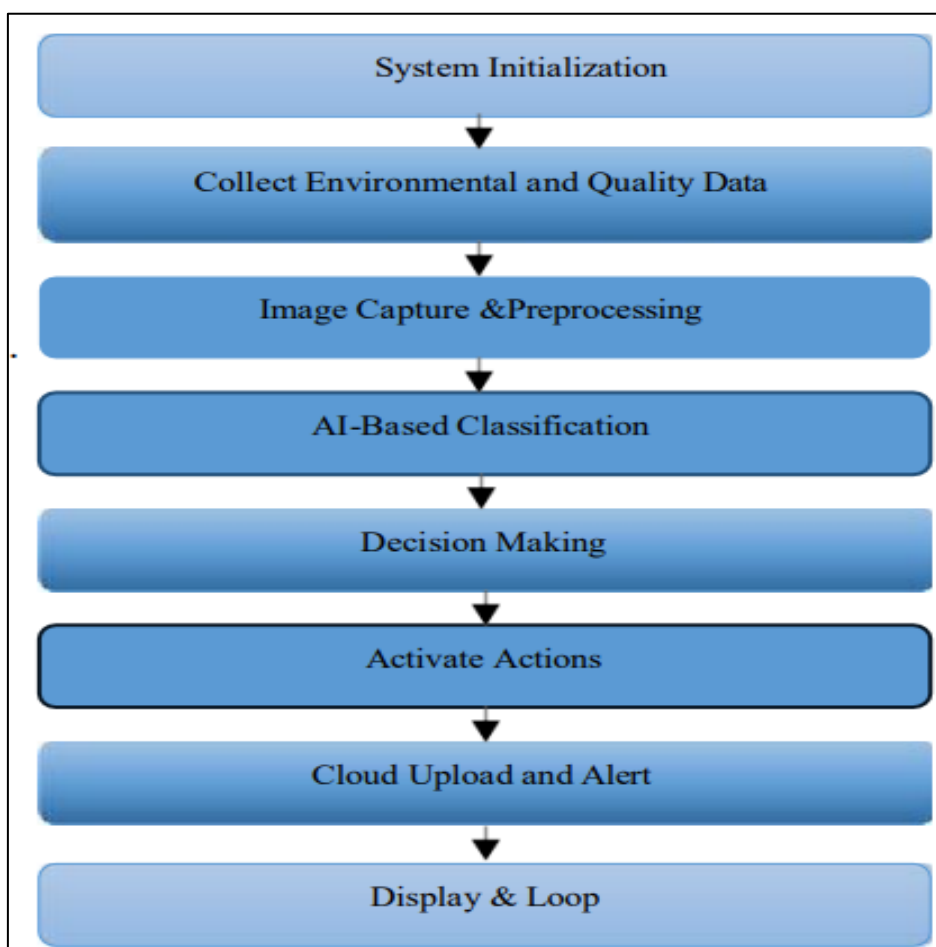

Fig 10 Flowchart of Smart Monitoring System Using AI

The flowchart 10 illustrates the operational workflow of an AI-powered smart monitoring system. It begins with System Initialization, followed by Collecting Environmental and Quality Data using sensors. Next, Image Capture & Preprocessing prepares visual input for analysis. The AI-Based Classification stage interprets the data to identify anomalies or patterns. Based on this, the Decision-Making module evaluates outcomes and triggers the Activate Actions phase, such as alerts or control mechanisms. Subsequently, data is sent to the Cloud image analysis. To supply chain managers, the monitoring means using cloud and real-time alerts contributes more to making decisions and transparency. On the whole, such an inventive approach significantly reduces the levels of food waste and enhances quality control as well as leads to sustainable cold chain logistics.

Upload and Alert system for remote access. Finally, the Display & Loop step ensures results are shown and the system re-initiates the process cyclically.

#### IV. RESULT & DISCUSSION

The developed AI-integrated IoT system was tested on a variety of perishable food items, including fruits and vegetables, under different storage conditions such as room temperature, refrigeration, and sealed containers. Using data from the DHT22, MQ-135, and pH sensors, the classification model categorized food items as Fresh, Warning, or Spoiled with an overall accuracy of 92.5%. Precision and recall were recorded at 91.2% and 93.8%, respectively, with most misclassifications occurring in borderline Warning cases during rapid humidity changes. In parallel, the vision-based convolutional neural network (CNN), trained on 1,200 labeled images, achieved an accuracy of 94.1%, precision of 92.6%, and recall of 95.7%, effectively identifying early signs of spoilage such as mold growth, discoloration, and surface deformities. The system's automated preservation mechanisms responded accurately in 98.7% of triggered events, where the pneumatic sprayer extended the freshness of at-risk produce by 48 to 72 hours, and the UV-C sterilization module reduced surface microbial load by approximately 85% within 10 minutes. Real-time data transmission to the ThingSpeak cloud was successful 98.9% of the time, with average latency under 3 seconds, and alert messages via email and SMS were consistently delivered within 5 seconds of anomaly detection. The complete system proved compact, low-cost, and power-efficient, operating for up to 12 hours on a standard portable battery. A 48-hour trial deployment in a cold-chain transport environment confirmed its robustness, continuous monitoring capability, and positive impact on reducing food spoilage during transit [9,10].

#### V. CONCLUSION

It is ensured that the perishable food remains fresh and safe due to an IoT-based quality control system with automated chemical spraying, which is a wise use of sensors, artificial intelligence, and edge computing. It enables immediate preservation actions such as UV sterilizing and sprays of preservatives by keeping continuous observation of climatic conditions and early signs of spoilage via sensor

readings and real time monitoring.

#### REFERENCES

- [1]. Krishnan, P., Ebenezar, U. S., Ranitha, R., Purushotham, N., & Balakrishnan, T. S. (2024, March). AI-driven intelligent IoT systems for real-time food quality monitoring and analysis. In *2024 International conference on trends in quantum computing and emerging business technologies* (pp. 1-5).
- [2]. IEEE.Kim, Wan-Soo, Won-Suk Lee, and Yong-Joo Kim. "A review of the applications of the internet of things (IoT) for agricultural automation." *Journal of Biosystems Engineering* 45, no. 4 (2020): 385-400.
- [3]. Kolikipogu, R., Shivaputra, Muniyandy, E., Maroor, J.P., Lakshmi, G.V.R., Konduri, B. and Naveenkumar, R., 2025. Improving food safety by IoT-based climate monitoring and control systems for food processing plants. *Remote Sensing in Earth Systems Sciences*, 8(2), pp.387-399.
- [4]. Padhiary, Mrutyunjay, Sunny V. Tikute, DebapamSaha, Javed Akhtar Barbhuiya, and Laxmi Narayan Sethi. "Development of an IOT-based semi-autonomous vehicle sprayer." *Agricultural Research* 14, no. 1(2025): 229-239.
- [5]. Vedantam, K.S., Jain, S.K., Panwar, N.L., Sunil, J., Wadhawan, N. and Kumar, A., 2024. Emergence of Internet of Things technology in food and agricultural sector: A review. *Journal of Food Process Engineering*, 47(8), p.e14698.
- [6]. Mishra, Nikita, S. K. Jain, N. Agrawal, N. K. Jain, Nikita Wadhawan, and N. L. Panwar. "Development of drying system by using
- [7]. Aamer, A.M., Al-Awlaqi, M.A. and Rausyan Fikri, M., 2025. Smart food logistics: design and test of an IoT-based food traceability system. *International Journal of Logistics Research and Applications*, pp.1-20.
- [8]. Radogna, A.V., Latino, M.E., Menegoli, M., Prontera, C.T., Morgante, G., Mongelli, D., Giampetruzzi, L., Corallo, A., Bondavalli, A. and Francioso, L., 2022. A monitoring framework with integrated sensing technologies for enhanced food safety and traceability. *Sensors*, 22(17), p.6509.
- [9]. Nagarajan, Senthil Murugan, Ganesh Gopal Deverajan, Puspita Chatterjee, Waleed Alnumay, and V. Muthukumaran. "Integration of IoT based routing process for food supply chain management in sustainable smart cities." *Sustainable Cities and Society* 76 (2022): 103448.
- [10]. Weiming, Su, and A. Yahaya. "An IoT- Driven architectural framework for a food quality monitoring and safety management 2system." *Front Soc Sci Technol* 6 (2024): 74-78.