

Auto Comforted Wheelchair for Quadriplegics

¹ Balamurugan K, ² Sindhu S, ³ Selva Suba Jenifer J, ⁴ Saranya P

¹ Assistant Professor: Department of Electrical and Electronics Engineering, Sri Ramakrishna Engineering College, Coimbatore, India

^{2,3,4} Student: Department of Electrical and Electronics Engineering, Sri Ramakrishna Engineering College, Coimbatore, India

Abstract:- According to a report from the World Health Organization, every year, 250,000-500,000 new spinal cord injuries occur around the world. A spinal cord injury shatters people's lives in a fraction of a second, leaving them paralyzed for the rest of their lives. To aid paraplegics, variety of electric wheelchairs exists, but these cannot be used by quadriplegics, i.e. persons who cannot move any of their body parts, except head. The concept of Smart Wheelchair is implemented to facilitate locomotion and localization of the quadriplegics. We use MEMS sensor to detect the head movements and corresponding signal is fed to the microcontroller. The microcontroller controls the wheelchair directions with the help of motor drive circuits. We also include the eye blink sensor and voice recognition sensors to overcome the limitations of the existing systems.

Keywords:- Quadriplegics; MEMS sensor; PIC16F877A; Eye Blink Sensor; Motor driver; Voice Recognizer.

I. INTRODUCTION

Mobility has become very important for a good quality of life. Loss of mobility due to an injury is usually accompanied by a loss of self-confidence. Designing a system with independent mobility for such disabled people is our aim in this project. Statistics show that 43 million are disabled, about 17% of 250 million; almost 1 out of 5 persons are disabled. 52% spinal cord injured individuals are considered paraplegic and 47% quadriplegic. Paralysis of both the arms and legs has been traditionally been called quadriplegia. Quadriplegics are limited in their motion and need some device to communicate with their wheelchair for movements without other's assistance. The primary cause of quadriplegia is a spinal cord injury, but other conditions such as strokes can cause a similar appearing paralysis. According to International Perspectives on Spinal Cord Injury, reported by World Health Organization and The International Spinal Cord Society, when the spinal cord is injured the brain cannot properly communicate and so movements are impaired.

A patient with complete quadriplegia has no ability to move any part of the body below the neck. Sometimes people with quadriplegia can move their arms, but have no control over their hand movements. Providing the quadriplegics with movement and helping them to be more independent is the main goal of this project. The idea is to design a new human-machine interface for controlling wheelchair by head movement. The System will detect the head movement and control the wheelchair that could operate in any direction i.e. Forward, Backward, Left and Right.

Various projects have been implemented to help handicapped people but our project mainly helps severely

handicapped people, with the aim of increasing their quality of life and allowing them to lead an independent lifestyle and greater chances of social integration.

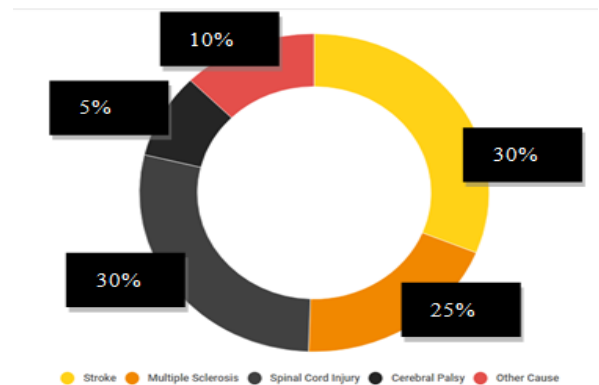

Fig 1:- Causes of quadriplegics

II. LITERATURE SURVEY

There were many previous works carried out on wheelchairs. These are a few of them which helped us to get an idea for our smart wheelchair.

In [1] the project presents the working of a robotic arm using voice control. The appropriate words to be recognized are first trained by the user using the speech recognition module. The words are stored in numbers ranging from 1 to 9. During working, when the user says a particular trained word into the microphone of the speech recognition module, the words are recognized by it and corresponding BCD of the number in which the word is stored is taken out as the output. According to the inputs received by the microcontroller, appropriate signals are now sent to motor driver to rotate the required motor in the specific direction.

In [2] the system operates by taking head movement as input signal to control the motion of wheelchair in any direction. A MEMS sensor (or) accelerometer is used to track the movement. A cap is placed on the head and sensor is connected to it. The variations produced by the sensor according to head movement are trapped and fed as input to microcontroller. The microcontroller takes decision based on the inputs provided and controls the wheelchair. The main disadvantage of the project is that, the cap which measures the head movement is fixed while starting and user cannot look around in case of emergency while the wheelchair is moving.

In [3] the paper describes the design of a wheelchair controlled by tilt sensor. Tilt sensors are used to provide

forward, backward, left and right movement of wheelchair with respect to movement of the head. The tilt sensors are connected in a potential divider circuit that generates appropriate voltage signals. These signals are fed to a diode logic circuit that converts these signals into electrical signals required to move motors in the wheelchair in appropriate directions.

In [4] the paper describes robotic wheelchair using accelerometer. The head-tilt movement is used to accelerate the wheelchair. The project also comprise of eye blink sensor to start and stop the wheelchair. In addition, the same head-tilt is used to communicate with the devices in a room for example: a fan. This communication is done using a RF transmitter and receiver. Using this, the person can control various devices easily. Drawback: Tilt sensor (or) accelerometer cannot measure 3-axis acceleration. Therefore separate sensors are used for controlling the direction.

In [5] paper mainly focuses on gesture recognition technique which is done by accelerometer. The hand gesture recognition signals given from the user is transmitted through wireless communication. An ADF-7020 transceiver for wireless transmission of accelerometer signal to control the wheelchair is used.

In [6] idea is to create a head motion controlled system which allows movement of patient's wheelchair depending on movement of head. The ultrasonic sensors are used to detect the forward and backward motion of the head. The disadvantage this project is due to the fixed cap which refrain the users from normal head movement. The disadvantage of ultrasonic sensor is that, the distance measured may not be appropriate for controlling the wheelchair.

In [7] the wheelchair will work based on the head movement of the user. The recognized gestures are used to generate motion control commands to the controller so that it can control the motion of the wheelchair according to the user intention. Design and development of the head motion controlled wheelchair has been achieved using accelerometer and PIC microcontroller.

In [8] paper describes the design of a smart, motorized, voice controlled wheelchair using embedded system. Arduino microcontroller and speaker dependent voice recognition processor have been used to support the navigation of the wheelchair. The direction and velocity of the chair are controlled by pre-defined Arabic voice commands. Arduino receives coded digital signals in order to control the function of the chair accordingly.

In [9] a voice operated robotic arm is used to pick and drop objects. The most important features are the voice control and image sensing method. The voice control module is used to control the robotic arm using voice commands and image processing is used to pick and place particular coloured object by the arm as per given command through the computer.

In [10] and [11] an attempt is made to propose a brain controlled wheelchair, which uses the captured signals from the brain and processes it to control the wheelchair. The interactions between neurons create an electric discharge which can be measured using Electroencephalography technique which deploys an electrode cap that is placed on user's scalp for the acquisition of the EEG signals which are captured and translated into movement commands by the arduino microcontroller. But according to [16], it is difficult to detect the brain signals since the neurons send numerous signals from our body. Therefore it leads to random directions due to various signals.

In [12] the system provides a unique method to prevent accident by using eye blink sensor and alcohol sensor. Whenever the driver starts the vehicle, the sensor senses the eye blink and measures the content of alcohol and automatically sends signal to buzzer. In this system the outputs of sensors are given to the microcontroller for comparison.

In [13] the project is to implement speech recognition technology in wheelchair to move it automatically by using voice command. Input is given through Microphone which is inbuilt on the wheelchair. Joystick technology is replaced with voice technology by which wheelchair becomes too easy for operation. The disadvantage is that under noisy conditions total instructions cannot be executed.

In [14] and [15] paper introduces voice control of the robotic arm and the mechanical design of robotic arm. By using special software developed in Microsoft visual studio, the commands are passed to the robot as serial codes. The author of the paper have programmed the control hardware to recognize simple pick up and release operation of the hand, such as a realistic hand.

III. PROPOSED MODEL AND IMPLEMENTATION

The system operates on basis of head movement which is fed as an input signal to control the motion of wheelchair in any direction. Voice control is used to only move the robotic limb that attaches a head cap on the individual. The head cap analyses the head movement of the person and microcontroller accelerates the vehicle. The proposed system also utilizes eye blink sensor to turn off the entire system when there is no eye movement for a certain period of time.

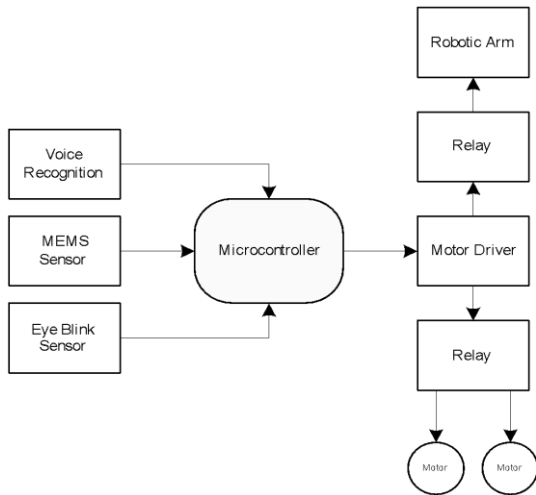

Fig 2:- General block diagram of Smart Wheelchair

A) MEMS Sensor

Tiny integrated devices (or) systems that combine mechanical and electrical components are created using MEMS technology. When acceleration is applied, a force develops which displaces the mass. This accelerometer is 3-axis which reads off the X, Y and Z acceleration as analog voltages. Analog voltage will be scaled around [0-3] V depending on both positive and negative values of voltage. By measuring the amount of acceleration due to gravity, an accelerometer can figure out the angle it is tilted with respect to earth.

The user selects the bandwidth of the accelerometer using the C_x , C_y and C_z capacitors at the X_{out} , Y_{out} and Z_{out} pins. Bandwidths can be selected to suite the applications, with a range of 0.5 Hz to 1600 Hz for the X and Y axes, and a range of 0.5 Hz to 550 Hz for the Z axis.

B) Voice recognizer

Voice recognition module, which can recognize as much as 15 voice instruction and be suitable for most cases involving voice control. This board analyzes the analog signal received, compares with the data stored in external RAM and finally outputs a corresponding 8 bit Data. This 8 bit data can be directly connected to a port of microcontroller.

C) Motor

DC geared motors are used in our wheelchair to drive the system in forward, backward, left and right directions. DC motors have been used powered by a rechargeable battery of 12v,7 Ah. Two motors are used for driving the wheelchair and motor driver controls the actions.

D) Motor driver

We have two wheels together and each is controlled simultaneously by motor driver ULN2003A. It comprises of 7 independent Darlington pairs that generate high current output of up to 1 ampere. This IC is used to drive 4 relays that operate the motors in the wheelchair and 2 relays that operate the robotic arm.

Motor 1		Motor 2		Direction
Input 1	Input 2	Input 1	Input 2	
0	1	0	1	Forward
1	0	1	0	Reverse
0	1	1	0	Right
1	0	0	1	Left

Table1: Truth Table representing the working of Motor Driver

E) Eye Blink Sensor:

The eye is illuminated by an IR led, which is powered by the +5v power supply and the reflected light is recorded by an IR photo diode. This eye blink sensor is IR based; the variation across the eye will vary as per eye blink. This to know the eye is closing or opening position. This output is given to the logic circuit to indicate the alarm. This can be used for project involves controlling accident due to unconscious through eye blink.

5V (High) - LED ON When Eye is Close

0V (Low) - LED OFF When Eye is Open

IV. MECHANICAL DESIGN

The Mechanical design includes wheelchair frame designing and robotic arm designing.

The wheelchair frame has been made using a chassis of Mild Steel that is rectangular frame supported by two castor wheels and rear drive wheels. The power is provided to the rear wheels using DC geared motor. Castor wheels act as free wheels to allow easy rotation of the wheelchair. The drive shaft includes custom designed hubs for mounting the motor onto the shaft of wheels through a gear transmission system. A gear reduction using two spur gears with the gear ratio of 1:10 is used to drive the rear wheel. This is used to reduce the load on the motor shaft while a person sitting on the wheelchair operates it. Complete chassis is made using welding and lathe machining. A chair is fitted on the top of the chassis for sitting and it is fitted using welding joints on the base.

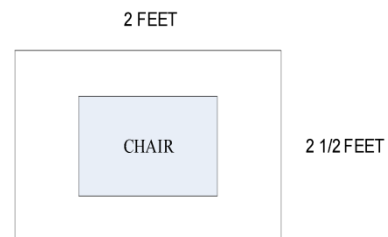

Fig 3:- Design of Basement of Wheelchair

V. CIRCUIT DIAGRAM

The MEMS sensor connection to the PIC microcontroller is shown in Fig4. The sensor detects the head movement of the user in 3-axis i.e. x, y and z axis

respectively. The sensor output is given to the analog pins of the microcontroller. The output of the MEMS sensor will be analog signals. The microcontroller analog pins consist of A/D converter which converts them to digital signals for controlling the wheelchair direction.

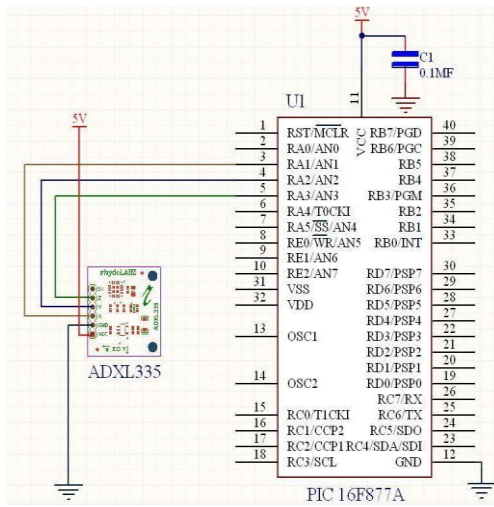

Fig 4:- Circuit Diagram of MEMS Sensor

The motor driver connection is shown in Fig5. The motor driver amplifies the current from the microcontroller and controls the operation of the motor. Depending upon the input from the microcontroller the motor driver controls the rotation of the motor i.e. forward or backward rotation respectively. The motor driver controls two motors which are attached to the back wheel of the wheelchair.

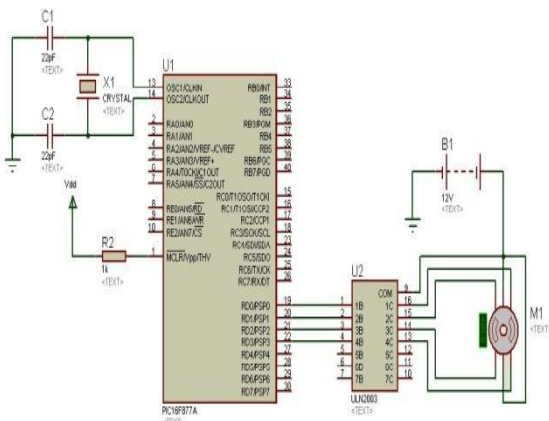

Fig 5:- Circuit Diagram of Motor Driver

VI. SIMULATION

Embedded systems combine hardware and software to perform predefined tasks. The source code for the microcontroller is written in embedded C and simulated using Proteus 8.

The simulation consists of 3 rheostats for varying the input to the microcontroller. Since adxl335 library is not inbuilt in Proteus, we use rheostats. Depending upon each rheostats value, the microcontroller displays the respective direction in the LCD display and according to that the transistors get operated and turn on the relay. When the

relay is operated the motor gets operated in the respective direction. A virtual terminal is used as input, if the input is '1' then the robotic arm relay gets operated and the motor runs, similarly, if it is '2' the relay gets operated and the motor stops. This works according to voice recognition input.

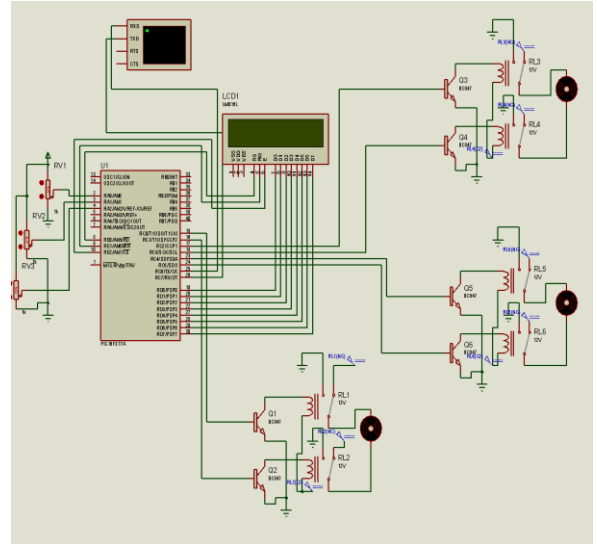

Fig 6:- Simulation in Proteus

VII. CONCLUSION

It proves to be an effective solution for quadriplegic patients with more than 45% disability or for the patients with spinal cord injury who could not move hands and legs for driving a manual or automatic wheelchair. This System proves better than automatic joystick powered wheelchairs in terms of ease of operation and control. Also, the project comes out to be economical as compared to other available wheelchairs in the market.

More features can be included in future in the wheelchair to make it much more sophisticated. The [4] paper describes that the wheelchair can communicate with other devices in particular room using RF transmitter and receiver. Similarly, we can include RF transmitter and receiver to control certain devices in the room by implementing voice recognition module. Another updation is that the wheelchair can be converted to bed using motor.

VIII. ACKNOWLEDGMENT

The authors gratefully acknowledge the Department of Electrical and Electronics Engineering, Sri Ramakrishna Engineering College, Coimbatore, India for supporting them to do their project work.

REFERENCES

- [1]. [AbhinavSalim, Ananthraj C R, PrajinSalprakash, Babu Thomas, "Voice Controlled Robotic Arm", International Research Journal of Engineering and Technology, Vol.4, Issue 4, P. 2121-2124, April 2017.
- [2]. AshaArvind, Harikrishnan R, "Head Movement Controlled Wheelchair Using Mems Sensors", International Research Journal of Engineering and Technology, Vol.3, Issue 5, P. 1135-1138, May 2016.

- [3]. Satish Kumar, Dheera, Neeraj, Sandeep Kumar, "Design and Development of Head Motion Controlled Wheelchair", International Journal of Advances in Engineering and Technology, Vol.8, Issue 5, P. 816-822, October 2015.
- [4]. Collen Nelson, Nikitha S Badas, Saritha I G, Thejaswini S, "Robotic Wheelchair Using Eye Blink Sensors and Accelerometer Provided with Home Appliance Control", International Journal of Engineering Research and Applications, Vol.4, Issue 5, P.129-134, May 2014.
- [5]. Saravanan P.D, Ramakrishnan M, Ligi K, "Auto-comforted Wheelchair System for Physically Challenged", IEEE 2nd International Conference on Knowledge Collaboration in Engineering, P.27-28, March 2015.
- [6]. RamanpreetKaur, Satvir Singh, BikrampalKaur, "Technology for the Aid of Quadriplegics", an International Journal of Engineering Sciences, Vol.17, P.277-281, January 2016.
- [7]. Abhishek Gupta, Neeraj Joshi, Nikhil Chaturvedi, Sonam Sharma, VikashPandar, "Wheelchair Control by Head Motion Using Accelerometer", International Journal of Electrical and Electronics Research, Vol.4, Issue 1, P.158-161, March 2016.
- [8]. Ali A. Abed, "Design of Voice Controlled Smart Wheelchair", International Journal of Computer Applications, Vol.131, Issue 1, P.32-38, December 2015.
- [9]. Rajesh Tiwary, "Robotic Arm with Voice Controlled and Image Processing: - A Review", the Journal of Science, Technology and Humanities, 2015.
- [10]. Mehulpatel, RishikeshBhavsar, "Design and Implementation of Brain Controlled Wheelchair", International Research Journal of Engineering and Technology, Vol.4, Issue 3, P. 599-602, March 2017.
- [11]. SelvaganapathyMonoharan, NishavithriNatarajan, "Brain Controlled Wheelchair for Physically Challenged People using Neuro-Sky Sensor", International Journal of Innovative Research in Science, Engineering and Technology, Vol.4, Issue 12, P.11985-11992, December 2015.
- [12]. Deepa K B, Chaitra M, Ankit Kumar Sharma, Sreedhar V S, Prashanth Kumar H.K, "Accident Prevention by Eye Blink Sensor and Alcohol Detector", International Journal of Engineering Research, Vol.4, Issue 7, P.351-354, July 2015.
- [13]. Rahul Agarwal, AkramSiddiqui, Kuvendra Singh, ArjunSolanki, LavitGautam, "A Voice Controlled Wheel Chair Prototype for a Medically Challenged", International Journal of Engineering Trends and Technology, Vol.34, Issue 2, P.55-57, April 2016.
- [14]. Musa HakanAsyali, Mustafa Yilmaz, Mahmut Tokmakci, "Design and Implementation of a Voice Controlled Prosthetic Hand", Turkish Journal of Electrical Engineering and Computer Science, Vol.19, Issue 1, P.33-46, 2011.
- [15]. Shyam.R. Nair, Shalini. R. Nair, "Design of a Voice Controlled Robotic Arm for Picking and Placing an Object", IOSR Journal of Engineering, Vol.2, Issue 4, P.670-673, April 2012.
- [16]. <http://illuminate.usc.edu/240/thought-controlled-wheelchair/>