

Voltage Recovery Control Techniques of Grid-Connected Variable Speed Wind Turbines at a Short Circuit

Rezq Mohammed Moustafa
New Urban Communities Authority
(NUCA), Ministry of population
Cairo, Egypt.

Dr. Ahmed El Biomy Mansour
Prof., Electrical Engineering Dep.,
Al Azhar University
Cairo, Egypt.

Dr. Abd El Ghany Mohammed
Prof., Electrical Engineering Dep.,
Helwan University
Cairo, Egypt.

Abstract:- The documented investigation in this paper examines main power quality for wind turbines and its connection with the public grid. This main goal has been to investigate most popular type of wind turbines which are grid connected using doubly-fed induction generators (DFIG) at normal operation, as well as voltage control of these wind turbines after clearing a lines short circuit in the utility grid. This paper introduces the configuration of main portions of grid connected turbines, which have an importance in the wind power plants operation. It also proposes a new compact modeling of these wind turbines, which has a feature that the expressions of most plant portions are free of any complex or details that described in other past models.

Most of last models are spotted on the normal operation of single wind turbines, without consideration of gird interaction faults. The proposed control techniques are new combined and concentrated on the voltage recovery, which plays very important role in the power quality and stability of wind turbines plants which are connected with the grid.

Net simulation results show that the combination of pitch control and dynamic slip control could to have power system stability efficiently, and restore the voltage to its normal condition. A simulation of wind turbine using pitch control and dynamic slip control are developed by the simulation program is called power system computer aiding design (PSCAD) and carried out the stability investigations respecting to short circuit in external power lines system. After clearing of the fault, the recovery of voltage at the terminals of wind turbine should to rebuild, then the wind power turbine should going to its normal case.

Control of the pitch angle or generator slip can adjusting the aerodynamic torque and the electromagnetic torque at the turbine which can be help to recovery the voltage at the terminals of wind turbine.

The results of case study simulation are proved that pitch and dynamic slip controls are methods to improve the recovery of voltage effectively and going to the system stability quickly, especially the combined controls of dynamic slip and pitch angel together.

Keywords:- Wind Turbines, Wound Rotor, Doubly Feed Induction Generator, Pitch, and Dynamic Slip.

I. INTRODUCTION

At last, the generation of wind power has high considerable over the worldwide market. The research supports the wind energy value, which fast the wind power development [1].

According to the specifications, at the external network and in case of short circuit fault, the voltage should to be rebuild without disconnection of wind turbines which is associated with dipped source voltage or high inrush current [3]. Because of when wind power is high considerable in power grid generation, so any disconnection of these large amount of turbines will threaten the stability of power system to be an unacceptable case.

At the short circuit, the transient inrush current is arising and the terminals voltage is dipped, leading to reduction of the electrical power because the electromagnetic torque is previously reduced [2]. The voltage recovery after cleared fault should to be assisted by relay protective adjustment or compensation of reactive power [3]. The relay settings are necessary to stay grid lines for longer time during the short circuit. The concentration of this paper is the voltage recovery assisted by controls techniques in turbines. A proposed simulation of wind turbine which controlled by pitch or dynamic slip is simulated PSCAD program.

The simulation Results show that the combined control of pitch and dynamic slip is the effective method to recovery the voltage and going to high stability of the power system.

II. WIND POWER TURBINE MODELING

Model of wind turbine can be divided the following main portions:

A. Modeling of wind

For wind model, should to study the dynamics connections between utility grid and the large farms of wind turbines [6]. The wind modeling is shown as in (Figure 1), which built by two parts [4] [7]. The first portion of modeling is wind turbine rotor, which include rotation and blades of wind turbine so are rotating. The modeling of wind turbine rotor includes wind speed v_{eq} [9]. The second portion of modeling is park scale, which simulated the wind turbine hub speed v .

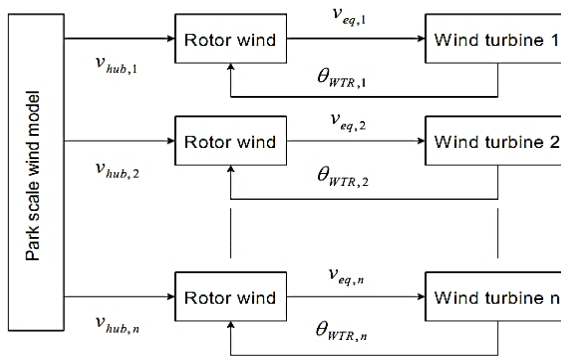

Fig 1:- Wind Model

B. Modeling of the Wind Turbine Aerodynamics

Wind turbines generation depend on the connection relationship between the turbine rotor and wind. The blades of wind turbine producing the motion power from the air flow, then convert it into rotational energy, and then deliver it to the mechanical drive unit into the final to the electrical generator [8].

The mathematical relationship between wind speed and aerodynamic power is expressed as in next equations:

$$P_W = \frac{1}{2} \rho \pi R^2 v_{eq}^3 C_P(\theta, \lambda) \quad (1)$$

The aerodynamic torque is expressed as:

$$T_W = \frac{1}{2} \rho \pi R^2 v_{eq}^2 C_P(\theta, \lambda) / \lambda \quad (2)$$

Where; P_W is extracted aerodynamics power from the wind [W], T_W is the extracted aerodynamics torque from the wind [Nm], ρ is density of the air [kg/m³], R is the radius of turbine rotor [m], v_{eq} is equivalent wind speed [m/s], θ is the rotor angle of pitching [deg], $\lambda = W_{WTR} R / v_{eq}$ is speed tip ratio, W_{WTR} is the speed of turbine rotor [rad/s], and C_P is power coefficient.

Approximations of mathematical relationship is delivered to calculation of these values C_P at angle θ and λ . Here, the next approximation is used:

$$C_P(\theta, \lambda) = 0.22 \left(\frac{116}{\lambda_i} - 0.4 \theta - 5.0 \right) e^{\frac{-12.5}{\lambda_i}} \quad (3)$$

With

$$\lambda_i = \frac{1}{\frac{1}{\lambda + 0.08\theta} + \frac{0.035}{\theta^3 + 1}} \quad (4)$$

C. Mechanical modeling of wind turbine

The mechanical modeling is related to the wind turbine's dynamic parts that contribute the connection with the utility grid. The drive train is considered because of it has high effective impact on the net output power, which produced from turbine, while the other mechanical system parts has small effect, so they are not considered in this modeling [6].

The mechanical modeling of drive train is recognized as in the following equation:

$$J_{WG} \frac{dw_{WTR}}{dt} = T_W - T'_G - D w_{WTR} \quad (5)$$

Where; J_{WG} is the mechanical inertia of turbine and generator [kg·m²], w_{WTR} is the speed of turbine rotor [rad/s], T_W is the input torque of turbine aerodynamic [Nm], T'_G is electromagnetic torque of the generator referred to the low side speed [Nm], and D is coefficient of the friction [Nm/rad].

The aim of the voltage recovery study in stability case, and is not focused on which fault situation the wind turbines will lose stability, but proposing effective measures or control strategies for wind turbine voltage recovery in unstable situations [14].

D. Modeling of Electrical Components

PSCAD program provides modeling of the electrical turbine components, as electrical generator to convert mechanical power to electricity, transformer to grid linkage and capacitor banks to compensation of reactive power. In this case study, the electrical generator is a induction generator which has wound rotor resistance [12].

E. Modeling of Control System

The controlling of wind turbine is by two control techniques: pitch control using regulation of blades pitching angle, and dynamic slip control using variation of adding rotor resistance. The control in turbine dynamic slip and pitch is adjusted electromagnetic torque and aerodynamic torque respectively. When the turbine controlled using slip value of coupling electrical generator, its out power is smoothed fluctuation. The slip adjustments from full value of rotor

resistance till short circuit can be done by a switching semiconductor device as shown in the following (Figure 2) [13].

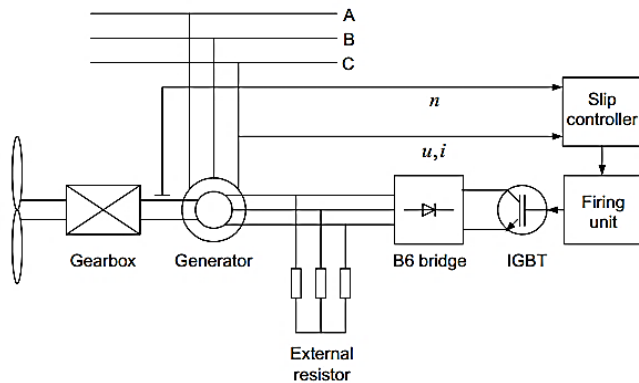

Fig. 2:- Dynamic control of electrical generator slip by external resistor using a switching semiconductor device.

The average rotor resistance which is series connected is evaluated in next equation:

$$r_a = D_s r \tag{6}$$

Where; r_a is the average rotor resistance in generator [Ω], r is full value of added resistor at external rotor series circuit [Ω], $D_s = T_{off}/T_t$ is the duty cycle of semiconductor switching, where T_{off} is off switching period [s] and T_t is switching period [s].

Modeling of the turbine aerodynamics is proved that the efficient effect using the blades pitching variation [11]. Regulating rotor blades provides regulated or limited of the turbine power at abnormal cases (when wind velocity in high limit). When wind speed is over limited value, the output power should kept at rated and normal power generation using pitch control.

The basic mechanism of pitch control can be evaluated as in the following (Figure 3).

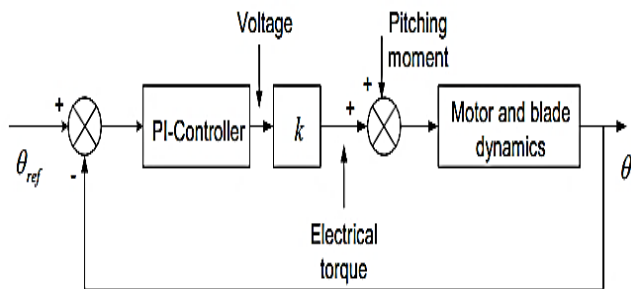

Fig. 3:- The basic control mechanism of closed loop pitch angle.

III. CASE STUDY AND RESULTS OF THE SIMULATION

The simulation on the system which shown as last (Figure 4), at bus bar (2) a load is consumed the demand power from farm of wind turbines coupling with wound rotor induction generator at bus bar (3), and by the external power which connected in series equivalent impedance is represented as a constant voltage source to delivery power in the utility grid.

(Table 1) presents the generator parameters which are belonging to wind turbine. At rated normalized operation; the turbine generator delivery active power 2.0 MW, which generates approximately (1/3) of the demand load at bus bar (2). In other side, the turbine generator absorbs 1.4 MVAR from the utility grid which connected.

The capacitors bank block is connected with wind turbine at the same bus bar. This capacitors bank delivery most reactive power MVAR which is required for the turbine generator, and a small percentage only is delivered to connected utility grid.

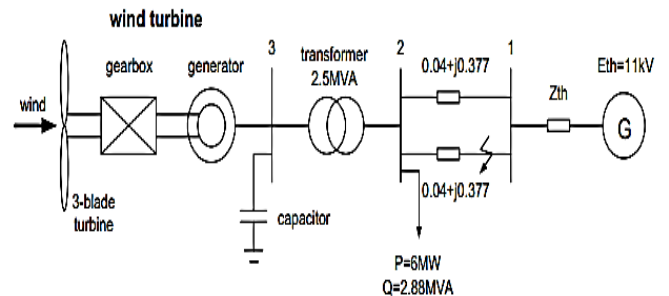

Fig. 4:- The case study diagram of wind turbine which is connected utility grid.

Abbreviation symbol	Parameter	Value
P_{rated}	Rated power	2.000 MW
U_{rated}	Rated voltage	0.690 kV
w_{rated}	Base frequency	315.161 rad/s
n	Stator/ rotor turns ratio	0.440
J_{WG}	moment of inertia	1.982 p.u.
D	Mechanical damping	0.020 p.u.
r_s	Stator resistance	0.018 p.u.
r_r	Rotor resistance	0.021 p.u.
L_{ls}	Stator leakage inductance	0.260 p.u.
L_{lr}	Rotor leakage inductance	0.351 p.u.
L_m	Mutual inductance	6.80 p.u.

Table 1:- Parameters of wound rotor generator.

The speed of wind turbine rotor and its corresponding output power at normal operation is shown as in (Figure 5).

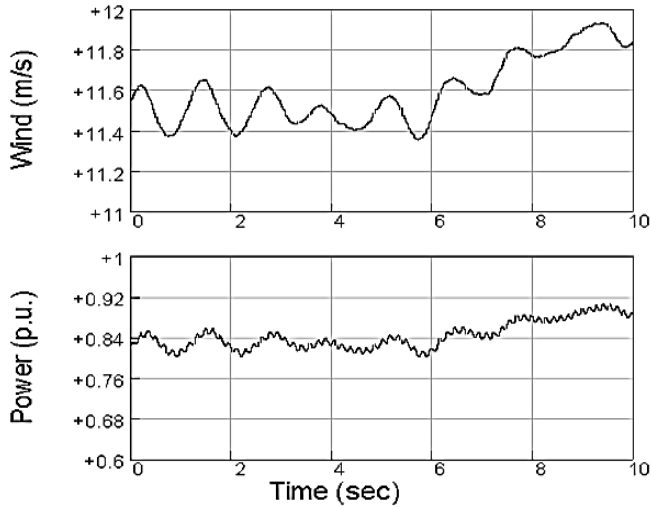

Fig. 5:- The speed of wind turbine rotor (m/s) and its corresponding output power (p.u) at normalized operation.

The short circuit fault occurs at one only of two parallel power lines, according to three phases to ground short circuit. At 2.0 sec the fault is beginning, and then the line is tripped after period time of 150 msec after fault beginning. Duration of fault period, the terminal voltage at wind turbine is dropped under limit then lead to reduction in the electromagnetic torque. Consequently this reduced value in the electromagnetic torque accelerates the turbine rotor speed, which causing increment in the kinetic rotation energy.

After fault is cleared, the electromagnetic turbine torque is rebuilt. If the rotation magnetic stored field is low than rotating stored mass, the rotation speed is over increased and the generator absorbs the high inrush current from the grid connected, till protection techniques devices tripped. At this situation, terminal voltage at (bus bar 3) is dipped then output power produced from turbine is dropped under limit, causing losing in system stability as shown as in (Figure 6) [14].

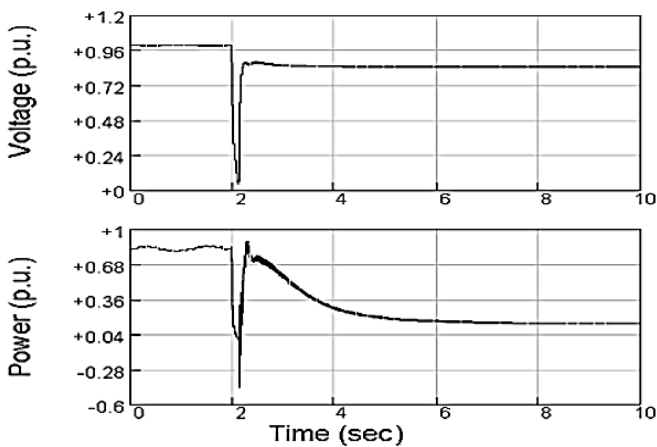

Fig. 6:- The wind turbine output power corresponding to terminal voltage, at system instability.

A. Control of Pitch angle

The wind turbine aerodynamics modeling, using regulating the pitch angle of turbine blades will control the aerodynamic torque of the wind turbine. After cleared fault, aerodynamics torque should go to reduction using angle increment in the pitch position. This pitch angle control slows rotor speed down, and then recovery the terminals voltage [7].

(Figure 7) is shown that the rebuilt voltage using control of pitch angle after the cleared short circuit, while T_w is the turbine aerodynamics torque (Nm) and T_g is generator electromagnetic torque (Nm). Through time period {2.0 sec to 2.15 sec} and duration the fault, the current arises over limit too, voltage is dropped, and electrical output power then electromagnetic torque has significantly reduction value. While aerodynamics torque is kept at constant, any decrement in electromagnetic torque will accelerate the rotor speed.

At 2.15 sec and after cleared fault, the flux air gap is recovered by absorbing high reactive power from utility grid. Consequently causes high and fast drawn inrush current, a voltage drops at turbine respectively. At 2.24 sec the pitch angle is controlled till reduce aerodynamics torque and the rotation energy. After voltage is recovered at 5.25 sec, the pitch angle controlled till produced power is more enough.

B. Control of Dynamic Rotor Slip

To increase the system electromagnetic torque also energy stored in rotating magnetic field after the fault, other effective control of rotor slip is applied using added resistor for the rotor circuit. Simplify that by the convenient semiconductor device, this mean that average rotor resistor is variable value. So torque slip curve of the electrical generator is re-drawn and the electromagnetic torque will change with high value.

In (Figure 8) the recovered voltage curves using control of dynamic rotor slip is clearly shown. On the time 2.25 sec approximately, the switching ratio between on and off time is controlled to push electromagnetic torque at high value, which forces the rotor speed to slow down. From other wise, the recovered voltage is regulated according to variable switching duty which in semiconductor device. On the time 4.5 sec approximately, the recovered voltage has been fully completed to normal condition [13].

C. Control of Combined Pitch Angle and Dynamic Slip

In this combined control technique, the voltage recovery is achieved using together generator rotor slip and pitch angle controls after a short circuit occurs. As illustrated in (Figure 9) and through 2.25 sec, the pitch angle and switching duty are applied to increase the electromagnetic torque, and at same time reduction of aerodynamic torque value.

Approximately at 3.75 sec, the recovered voltage has been fully completed to normal condition, and the pitch angle and switching duty are regulated and return to initial limits. The combined controls are better and very quicker than that in two last cases “the dynamic slip control or pitch control only”. Adjusting magnitudes of both the pitch and dynamic slip controls are less than the former two cases.

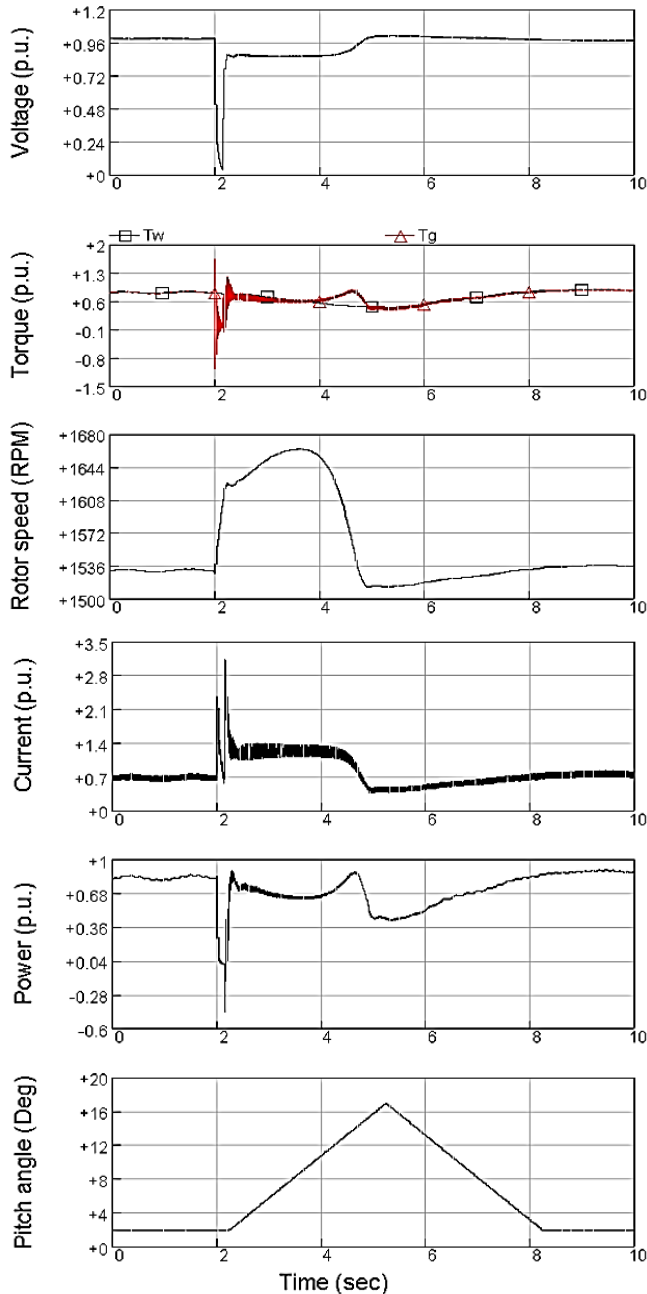

Fig. 7:- Voltage, electrical and mechanical torques, rotor speed, current, generator output power and pitching angel in condition of regulated pitch angle.

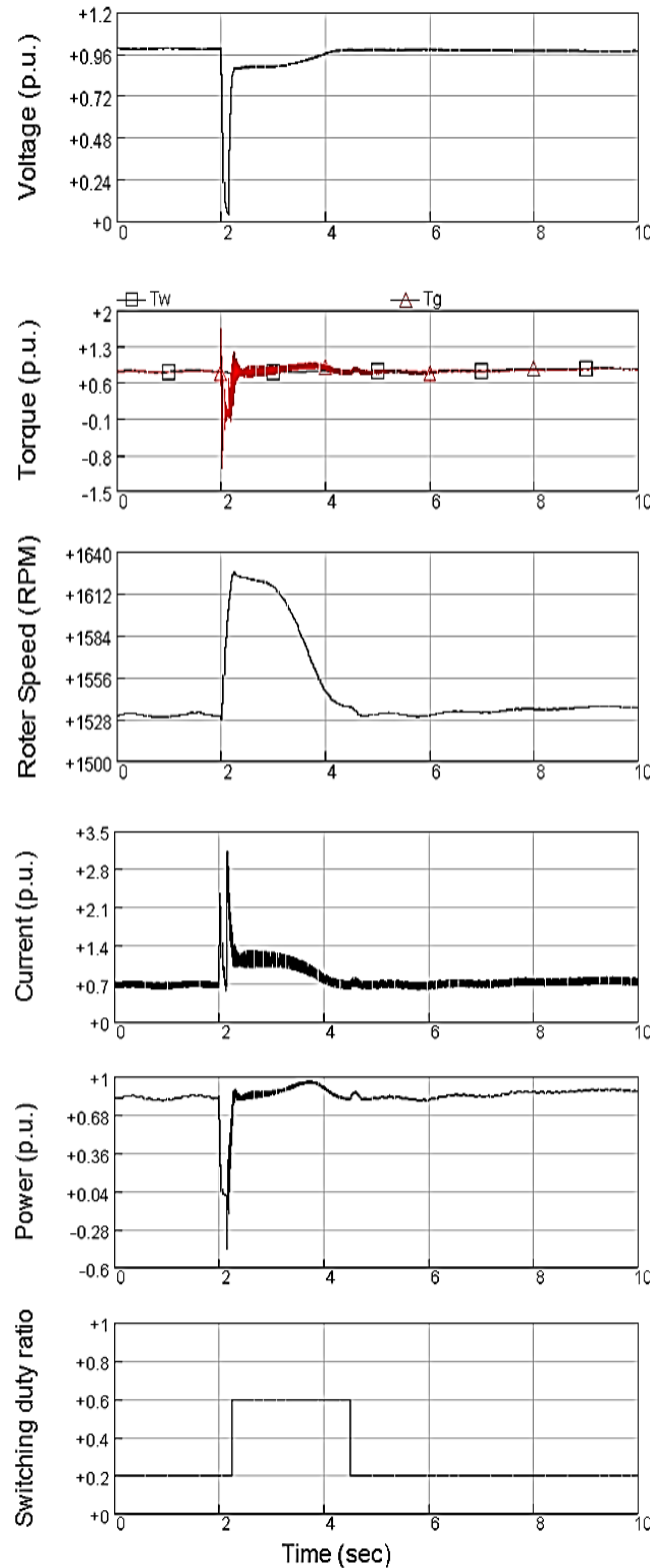

Fig. 8:- Voltage, electrical and mechanical torques, current, rotor speed, generator output power and switching ratio in condition of regulated dynamic slip.

IV. CONCLUSION

Proposed methods (in this paper) to recover the voltage after the cleared short circuit, using control of wind turbine to regulation of electromagnetic and aerodynamic torques. The results of simulated case study show that combined control of dynamic slip together in the same time pitch angle control are effective quicker response and for a wound rotor, which increases the grid stability.

Wind turbine which is grid connected via coupling of doubly fed induction generator (DFIG), where the generator rotor is interacted with the grid through power electronics converters. The improved stability, output active power and output reactive power are regulated by rotor circuit control. The performances and control techniques of most wind energy system is similar to wound rotor generators at short circuit fault.

REFERENCES

- [1]. I. El Samahy, El Saadany. " The Effect of DG on Power Quality in Deregulated Environment " paper, IEEE Power Engineering Society General Meeting, pp 2969 – 2976 , 2005.
- [2]. S. Khadem, M. Basu and M. F. Conlon. " Power Quality in Grid connected Renewable Energy Systems: Role of Custom Power Devices ", paper, International Conference on Renewable Energies, Granada, Spain, 23rd to 25th March, 2010.
- [3]. KAI YANG. "Wind-Turbine Harmonic Emissions and Propagation through A Wind Farm", thesis, Electric Power Engineering Group Division of Energy Engineering Department of Engineering Sciences and Mathematics Lulea University of Technology Skelleftea, Sweden, 2012.
- [4]. Tarek Hussein, Mostafa EL Fouly. " Wind Farms Production : Control and Prediction ", thesis, Electrical and Computer Engineering, Ontario, Canada, 2007.
- [5]. Anca D. Hansen, Poul Sorensen, Frede Blaabjerg and John Becho. " Dynamic modelling of wind farm grid interaction", paper, National Laboratory, Wind Energy Department, Denmark, VOLUME 26, NO. 4, PP 191 – 208, 2002.
- [6]. Yuan Kang Wu, Shih-Ming Chang, Li Tzo Chang, Dinh Thanh Viet, " Unit commitment in a high wind power penetration system", paper, 2018 5th International Conference on Power and Energy Systems Engineering, pp 19 – 21, Japan, September, 2018
- [7]. Majid Mehrasa, Edris Pouresmaeil, Amir Sepehr, Bahram Pournazarian, Mousa Marzband, João P.S. Catalão. " Control technique for the operation of grid tied converters with high penetration of renewable energy resources ", paper, Electric Power Systems Research 166, pp 18 – 28, 2019.

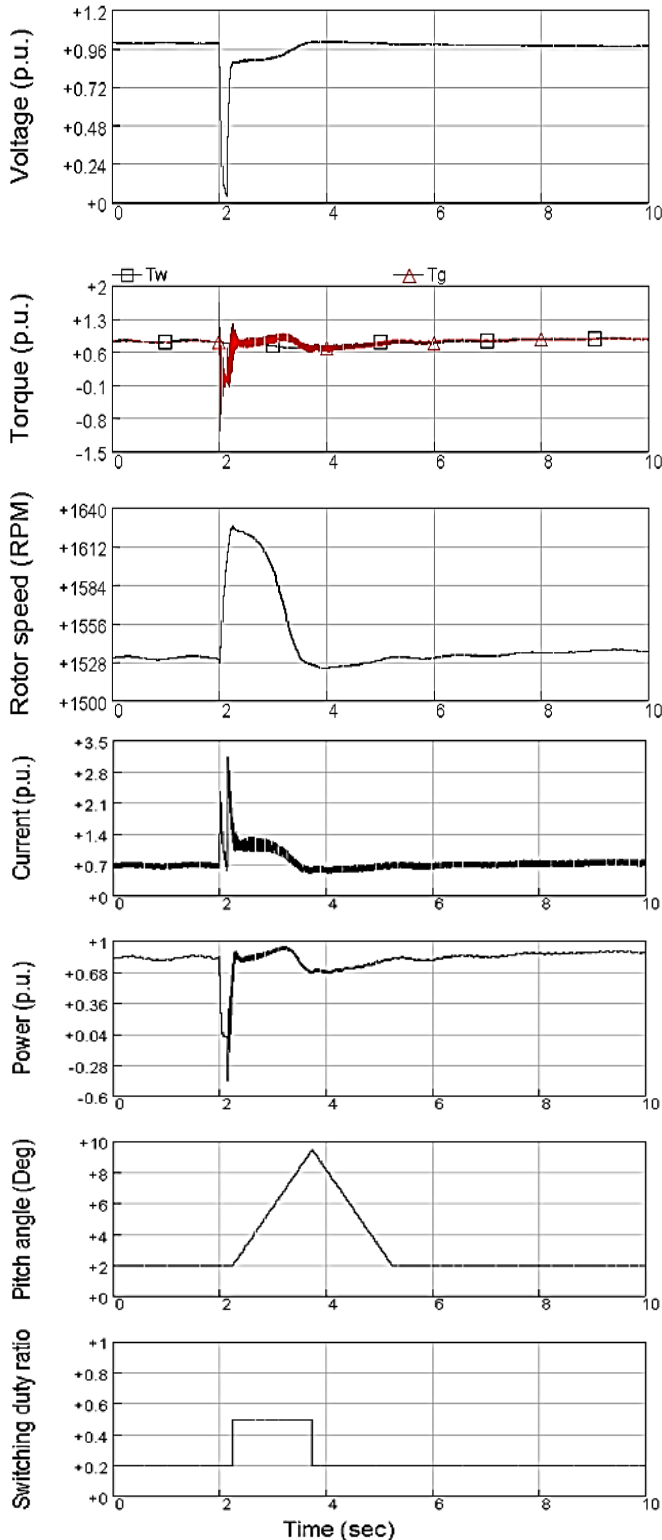

Fig. 9:- Voltage, electrical and mechanical torques, rotor speed, current, generator output power, pitching angle and switching semiconductor device ratio in condition of combined slip and pitch together.

- [8]. Sameh A. Eisa. “ Modeling dynamics and control of type 3 DFIG wind turbines: Stability, Q Droop function, control limits and extreme scenarios simulation”, paper, Electric Systems Research, pp 29 – 42, 2019.
- [9]. Zhe Ma, Pan Zeng, LiPing Lei. “ Analysis of the coupled aeroelastic wake behavior of wind turbine ”, paper, Journal of Fluids and Structures 84, pp 466 – 484, 2019.
- [10]. Y. Zhou. “ Wind Power Integration from Individual Wind Turbine to Wind Park as a Power Plant ”, thesis, Delft University of Technology, Anhui, China, 2017.
- [11]. Trinh Trong Chuong. “ The impact of wind power plant with doubly fed induction generators on the power systems ”, paper, International Journal of Science and Technology, <http://www.Academicjournals.org/IJSTER>, Vol. 4, January 2013.
- [12]. L. Xie, P. S. Carvalho, L. A. Ferreira, J. Liu, B. H. Krogh, N. Popli, M. D. Ilic. “ Wind integration in power systems : operational challenges and possible solutions ”, paper, IEEE 99, pp 214 – 232, 2011.
- [13]. C. K. Simoglou, E. A. Bakirtzis, P. N. Biskas, A. G. Bakirtzis. “ Optimal operation of insular electricity grids under high RES penetration ”, paper, Renewable Energy 86, pp 1308 – 1316, 2016.
- [14]. A. Trivedi, M. Singh. “ Repetitive controller for VSI in droop based AC microgrid”, paper, IEEE Trans. Power Electron. 32, pp 6595 – 6604, 2017.